

Accessori per teste a snodo e snodi sferici



Catalogo tecnico 2009

-Trasmissioni Industriali S.a.s. -

-Via Cuso 78, 36010 Z.I.Zanè (VI)
commerciale: +39 380 694 7342

E-mail: info@trasmissioniindustriali.com www.trasmissioniindustriali.com

Forcelle con foro filettato (DIN 71752 - ISO 8140 CETOP)

Clevises with threaded hole (DIN 71752 - ISO 8140 CETOP)

FK

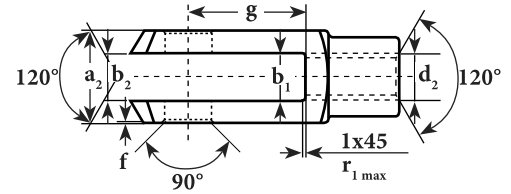
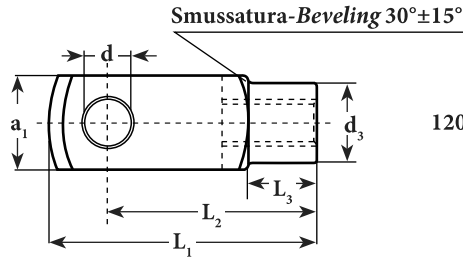

Sigla ¹⁾ Designation ¹⁾	Dimensioni mm Dimensions mm													Peso Weight ≈ Kg
	d H9	d ₂ 6H	d ₃ ±0,3	a ₁ h11	a ₂ +0,30 -0,16	b ₁ B13	b ₂	f ±0,2	g ±0,5	L ₁ ±0,5	L ₂	L ₃ ±0,3	r _{1 max} ±0,5	
FK 4X8	4	M4 X 0,7	8	8	8	4	4 ³⁾	0,5	8	21	16 ⁵⁾	6	0,5	0,005
FK 4X16	4	M4 X 0,7	8	8	8	4	4 ³⁾	0,5	16	29	24 ⁵⁾	6	0,5	0,007
FK 5X10	5	M5 X 0,8	9	10	10	5	5 ³⁾	0,5	10	26	20 ⁵⁾	7,5	0,5	0,009
FK 5X20	5	M5 X 0,8	9	10	10	5	5 ³⁾	0,5	20	36	30 ⁵⁾	7,5	0,5	0,013
FK 6X12	6	M6 X 1,0	10	12	12	6	6 ³⁾	0,5	12	31	24 ⁵⁾	9	0,5	0,015
FK 6X24	6	M6 X 1,0	10	12	12	6	6 ³⁾	0,5	24	43	36 ⁶⁾	9	0,5	0,021
FK 8X16	8	M8 X 1,25	14	16	16	8	8 ³⁾	0,5	16	42	32 ⁶⁾	12	0,5	0,037
FK 8X16FG	8	M8 X 1,0	14	16	16	8	8 ³⁾	0,5	16	42	32 ⁶⁾	12	0,5	0,037
FK 8X32	8	M8 X 1,25	14	16	16	8	8 ³⁾	0,5	32	58	48 ⁶⁾	12	0,5	0,054
FK 8X32FG	8	M8 X 1,0	14	16	16	8	8 ³⁾	0,5	32	58	48 ⁶⁾	12	0,5	0,054
FK 10X20	10	M10 X 1,5	18	20	20	10	10 ³⁾	0,5	20	52	40 ⁶⁾	15	0,5	0,074
FK 10X20FG	10	M10 X 1,25	18	20	20	10	10 ³⁾	0,5	20	52	40 ⁶⁾	15	0,5	0,074
FK 10X40	10	M10 X 1,5	18	20	20	10	10 ⁴⁾	0,5	40	72	60 ⁶⁾	15	0,5	0,116
FK 10X40FG	10	M10 X 1,25	18	20	20	10	10 ⁴⁾	0,5	40	72	60 ⁶⁾	15	0,5	0,116
FK 12X24	12	M12 X 1,75	20	24	24	12	12 ⁴⁾	0,5	24	62	48 ⁶⁾	18	0,5	0,121
FK 12X24FG	12	M12 X 1,25	20	24	24	12	12 ⁴⁾	0,5	24	62	48 ⁶⁾	18	0,5	0,121
FK 12X48	12	M12 X 1,75	20	24	24	12	12 ⁴⁾	0,5	48	86	72 ⁶⁾	18	0,5	0,175
FK 12X48FG	12	M12 X 1,25	20	24	24	12	12 ⁴⁾	0,5	48	86	72 ⁶⁾	18	0,5	0,175
FK 14X28	14	M14 X 2,0	24	27	27	14	14 ⁴⁾	1	28	72	56 ⁶⁾	22,5	1	0,178
FK 14X28FG	14	M14 X 1,5	24	27	27	14	14 ⁴⁾	1	28	72	56 ⁶⁾	22,5	1	0,178
FK 14X56	14	M14 X 2,0	24	27	27	14	14 ⁴⁾	1	56	101	85 ⁶⁾	22,5	1	0,258
FK 14X56FG	14	M14 X 1,5	24	27	27	14	14 ⁴⁾	1	56	101	85 ⁶⁾	22,5	1	0,258
FK 16X32	16	M16 X 2,0	26	32	32	16	16 ⁴⁾	1	32	83	64 ⁶⁾	24	1	0,282
FK 16X32FG	16	M16 X 1,5	26	32	32	16	16 ⁴⁾	1	32	83	64 ⁶⁾	24	1	0,282
FK 16X64	16	M16 X 2,0	26	32	32	16	16 ⁴⁾	1	64	115	96 ⁶⁾	24	1	0,411
FK 16X64FG	16	M16 X 1,5	26	32	32	16	16 ⁴⁾	1	64	115	96 ⁶⁾	24	1	0,411
FK 18X36	18	M18 X 2,5	30	36	36	18	18 ⁴⁾	1	36	94	72 ⁶⁾	27	1,5	0,390
FK 18X36FG	18	M18 X 1,5	30	36	36	18	18 ⁴⁾	1	36	94	72 ⁶⁾	27	1,5	0,390

¹⁾ Per filettatura a sinistra aggiungere il suffisso "L" (esempio: FKL..)

For left thread, suffix "L" is added (example: FKL..)

²⁾ Tipo con filetto CETOP thread type

³⁾ Tolleranza Tolerance B13: +0,33 ≈ +0,15

⁴⁾ Tolleranza Tolerance: +0,70 ≈ +0,15

⁵⁾ Tolleranza Tolerance: ± 0,3

⁶⁾ Tolleranza Tolerance: ± 0,4

Forcelle con foro filettato (DIN 71752 - ISO 8140 CETOP) Clevises with threaded hole (DIN 71752 - ISO 8140 CETOP)

FK

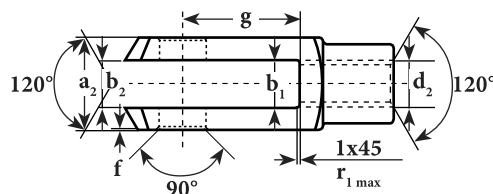
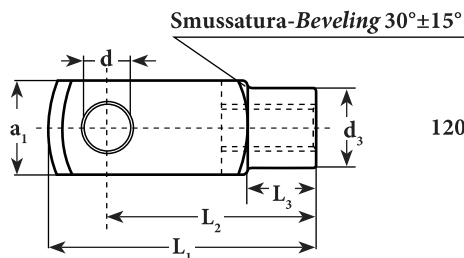

Sigla ¹⁾ Designation ¹⁾	Dimensioni mm Dimensions mm													Peso Weight ≈ Kg
	d H9	d ₂ 6H	d ₃ ±0,3	a ₁ h11	a ₂ +0,30 -0,16	b ₁ B13	b ₂	f ±0,2	g ±0,5	L ₁ ±0,5	L ₂	L ₃ ±0,3	r _{1 max} ±0,5	
FK 20X40	20	M20 X 2,5	34	40	40	20	20 ⁴⁾	1	40	105	80 ⁶⁾	30	1,5	0,55
FK 20X40.1 ²⁾	20	M20 X 1,5	34	40	40	20	20 ⁴⁾	1	40	105	80 ⁶⁾	30	1,5	0,55
FK 20X80	20	M20 X 2,5	34	40	40	20	20 ⁴⁾	1	80	145	120 ⁶⁾	30	1,5	0,8
FK 20X80FG	20	M20 X 1,5	34	40	40	20	20 ⁴⁾	1	80	145	120 ⁶⁾	30	1,5	0,8
FK 25X50	25	M24 X 3,0	42	50	50	25	25 ⁴⁾	1,5	50	132	100 ⁶⁾	36	1,5	1,1
FK 25X50.1 ²⁾	25	M24 X 2,0	42	50	50	25	25 ⁴⁾	1,5	50	132	100 ⁶⁾	36	1,5	1,1
FK 28X56	28	M27 X 3,0	48	55	55	28	28 ⁴⁾	1,5	56	148	112 ⁶⁾	40	2	1,5
FK 28X56FG	28	M27 X 2,0	48	55	55	28	28 ⁴⁾	1,5	56	148	112 ⁶⁾	40	2	1,5
FK 30X54.1 ²⁾	30	M27 X 2,0	48	55	55	30	30 ⁴⁾	1,5	54	148	110 ⁶⁾	40	2	1,44
FK 30X60	30	M30 X 3,5	52	60	60	30	30 ⁴⁾	1,5	60	160	120 ⁶⁾	42	2	1,97
FK 30X60FG	30	M30 X 2,0	52	60	60	30	30 ⁴⁾	1,5	60	160	120 ⁶⁾	42	2	1,97
FK 35X54.1 ²⁾	35	M36 X 2,0	60	70	70	35	35 ⁴⁾	2	54	188	144 ⁶⁾	54	3	2,93
FK 35X72	35	M36 X 4,0	60	70	70	35	35 ⁴⁾	2	72	188	144 ⁶⁾	54	3	2,93
FK 35X72FG	35	M36 X 2,0	60	70	70	35	35 ⁴⁾	2	72	188	144 ⁶⁾	54	3	2,93
FK 36X72	36	M36 X 4,0	60	70	70	36	36 ⁴⁾	2	72	188	144 ⁶⁾	54	3	2,93
FK 36X72FG	36	M36 X 2,0	60	70	70	36	36 ⁴⁾	2	72	188	144 ⁶⁾	54	3	2,93
FK 40X84.1 ²⁾	40	M42 X 2,0	70	85	85	40	40 ⁴⁾	3	84	232	168 ⁶⁾	63,5	5	5,64
FK 42X84	42	M42 X 4,5	70	85	85	42	42 ⁴⁾	3	84	232	168 ⁶⁾	63,5	5	5,34
FK 42X84FG	42	M42 X 2,0	70	85	85	42	42 ⁴⁾	3	84	232	168 ⁶⁾	63,5	5	5,34
FK 50X96	50	M48 X 5,0	82	96	96	50	50 ⁴⁾	3	96	265	192 ⁶⁾	73	5	7,86
FK 50X96.1 ²⁾	50	M48 X 2,0	82	96	96	50	50 ⁴⁾	3	96	265	192 ⁶⁾	73	5	7,86

**Su richiesta, disponibili in acciaio inox ed alluminio
Under request, stainless steel and aluminium available**

¹⁾ Per filettatura a sinistra aggiungere il suffisso "L" (esempio: FKL...)
For left thread, suffix "L" is added (example: FKL...)

²⁾ Tipo con filetto CETOP thread type

³⁾ Tolleranza Tolerance B13: +0,33 ≈ +0,15

⁴⁾ Tolleranza Tolerance: +0,70 ≈ +0,15

⁵⁾ Tolleranza Tolerance: ± 0,3

⁶⁾ Tolleranza Tolerance: ± 0,4

Forcelle con gambo filettato (DIN 71752 - ISO 8140 CETOP)

Clevises with male thread (DIN 71752 - ISO 8140 CETOP)

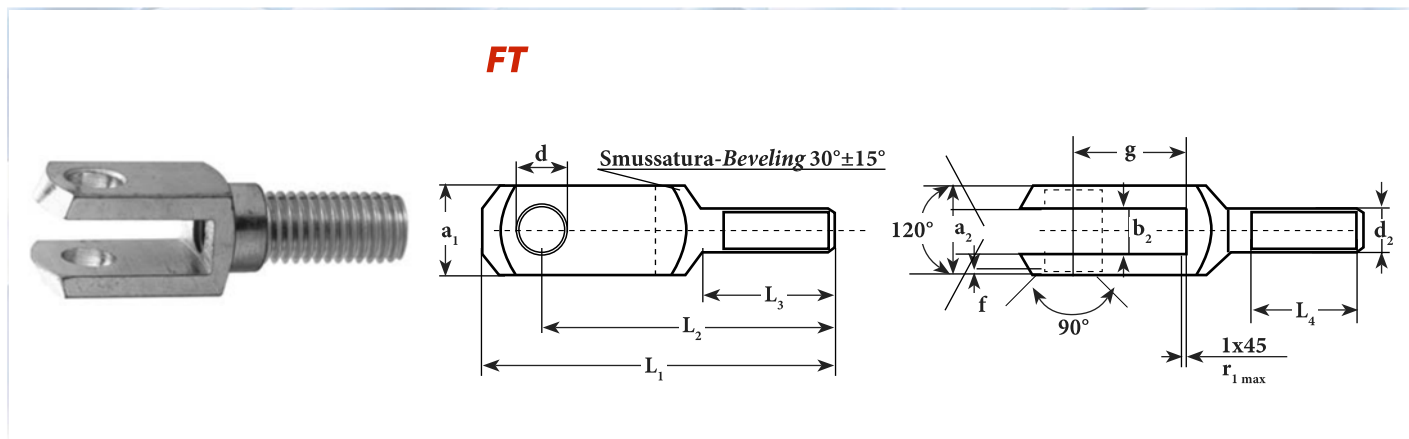

Sigla Designation	Dimensioni mm Dimensions mm												Peso Weight
	d H9	d ₂ 6g	a ₁ h11	a ₂ +0,50 -0,20	b ₂ +0,70 +0,15	f ±0,2	g ±0,5	L ₁ ±0,2	L ₂ ±0,4	L ₃ ±0,2	L ₄ min	r _{1 max} ±0,5	≈ Kg
FT 6X12	6	M6 X 1,0	12	12	6	0,5	12	44	37	20	15	0,8	0,015
FT 8X16	8	M8 X 1,25	16	16	8	0,5	16	57	47	25	20	0,8	0,036
FT 10X20	10	M10 X 1,5	20	20	10	0,5	20	69	57	30	25	0,8	0,068
FT 12X24	12	M12 X 1,75	24	24	12	0,5	24	82	68	35	30	0,8	0,122
FT 14X28	14	M14 X 2,0	27	27	14	1	28	94	78	40	35	1,2	0,171
FT 16X32	16	M16 X 2,0	32	32	16	1	32	108	89	45	40	1,2	0,282
FT 20X40	20	M20 X 2,5	40	40	20	1	40	134	109	55	50	1,5	0,550

Su richiesta, disponibili in acciaio inox ed alluminio
Under request, stainless steel and aluminium available

Clips per forcelle Spring pins for clevises



Sigla Designation	Dimensioni mm Dimensions mm							Peso Weight
	d H11	a	b	g	L_1 ≈	L_2 ≈	L_3 ≈	≈ Kg
CL 4X8	4	9,5	11	8	19	15	4,5	0,0015
CL 5X10	5	12	13,5	10	23	19	5,5	0,0025
CL 5X20	5	12	13,5	20	33	29	5,5	0,0031
CL 6X12	6	14	16	12	28	23	6,5	0,0046
CL 6X24	6	14	16	24	40	35	6,5	0,0052
CL 8X16	8	19	21,5	16	37	30	8	0,0106
CL 8X32	8	19	21,5	32	52	46	8	0,0116
CL 10X20	10	23	26	20	46	38	10	0,0194
CL 10X40	10	23	26	40	66	58	10	0,0205
CL 12X24	12	28	31	24	53	45	12	0,0331
CL 12X48	12	28	31	48	78	69	12	0,0350
CL 14X28	14	31	34	28	62	52	14	0,0472
CL 14x56	14	31	34	56	92	82	14	0,0508
CL 16X32	16	36	39	32	73	62	16	0,0694
CL 16X64	16	36	39	64	103	92	16	0,0744
CL 20X40	20	45	50	40	87,5	71,5	16	0,1300

Clips per forcelle ex CNomo Spring pins for ex CNomo clevises

Sigla Designation	Dimensioni mm Dimensions mm							Peso Weight
	d H11	a	b	g	L_1 ≈	L_2 ≈	L_3 ≈	≈ Kg
CL 8X16 CN	8	25	28	16	41	36	10	0,014
CL 12X25 CN	12	40	44	25	60	50	12	0,043
CL 16X33 CN	16	49	53	33	74	63	15	0,090
CL 20X40 CN	20	69	73	40	98	81	19	0,193

Su richiesta, disponibili in acciaio inox ed alluminio
Under request, stainless steel and aluminium available

Perni con testa cilindrica Pins with cylindrical head

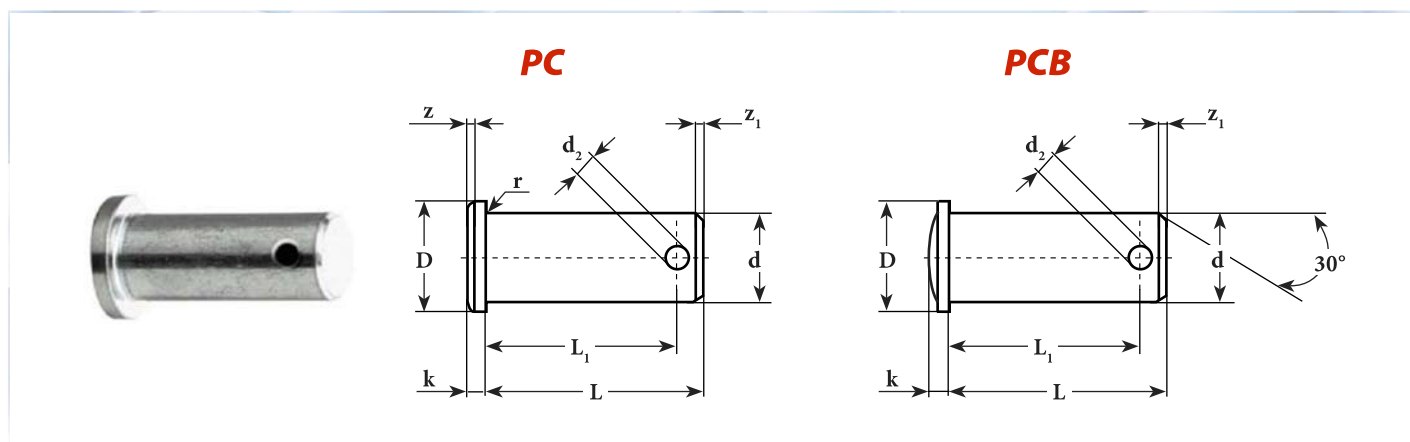

Sigla Designation	Dimensioni mm Dimensions mm									Peso Weight ≈ Kg
	d h11	d ₂ H14	D h12	k js14	L +0,3 ≈ 0	L ₁ +0,5 ≈ 0	r	z	z ₁ ≈	
PC 4	4	1	6	1	12	10	0,3	0,5	0,8	0,001
PC 5	5	1,2	8	1,5	15	12,3	0,3	0,5	0,8	0,003
PC 6	6	1,6	9	1,5	18	15,3	0,5	0,5	1	0,005
PC 8	8	2	12	2	23	19,5	0,5	1	1	0,010
PC 10	10	3,20	14	2	29	24,5	0,5	1	1,5	0,019
PC 12	12	4	17	3	35	29,5	0,5	1,5	2	0,034
PC 14	14	4	20	3	40	32,5	1	1,5	2,5	0,053
PC 16	16	4	21	3	45	37,5	1	1,5	2,5	0,067
PC 20	20	5	26	4	54	47	1	2	3	0,125
PC 25	25	6	32	5	67	59	1	2	3	0,260

Perni con testa bombata (sferica) Pins with barrel head (spherical)

Sigla Designation	Dimensioni mm Dimensions mm								Peso Weight ≈ Kg
	d h11	d ₂ H14	D	k js14	L +0,3	L ₁ +0,5	z ₁ ≈		
PCB 16	16	4	20	3,5	45	38,2	1,5	0,072	
PCB 18	18	5	25	3,5	50	43,5	1,5	0,104	
PCB 20	20	5	28	4	53	47	1,5	0,139	
PCB 25	25	6,3	34	5,5	67	59	1,5	0,266	
PCB 28	28	6,3	34	5,5	72	63,2	2	0,361	
PCB 30.6	30	6,3	36	5,5	67	59	2	0,383	
PCB 30.7	30	6,3	36	5,5	77	68,2	2	0,428	
PCB 35	35	8	45	7	87	76,5	2	0,677	
PCB 40	40	8	48	6	100	90	5	1,035	
PCB 42	42	8	48	7	100	90	5	1,151	
PCB 50	50	10	58	7	115	103	6	1,846	

Su richiesta, disponibili in acciaio inox ed alluminio
Under request, stainless steel and aluminium available

Perni con testa cilindrica e molla

Pins with cylindrical head and spring

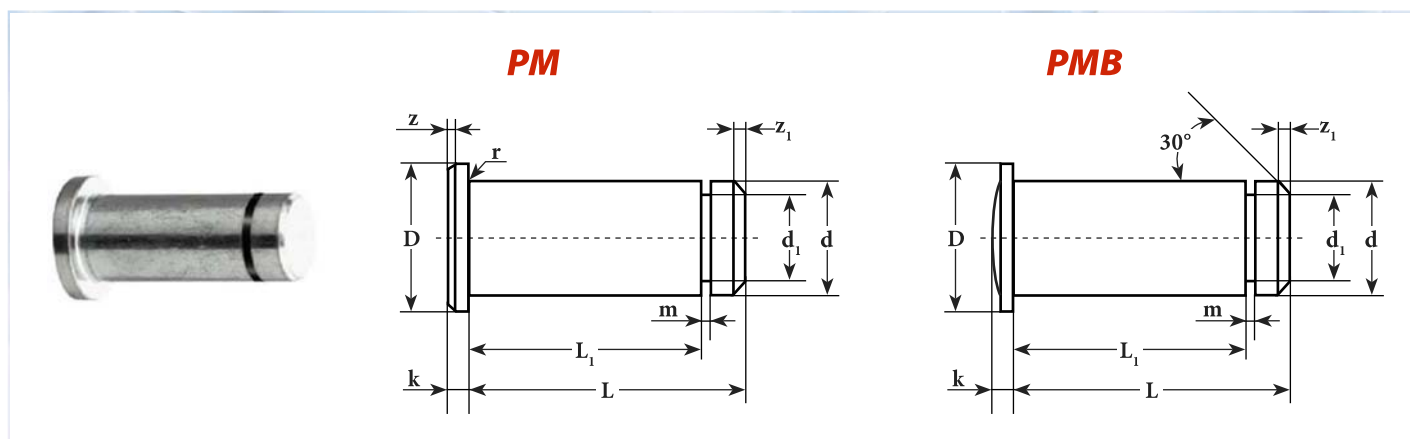

Sigla Designation	Dimensioni mm Dimensions mm										Peso Weight ≈ Kg
	d h11	d ₁ h11	D h12	k js14	L +0,3 ≈ 0	L ₁ +0,3 ≈ 0	m +0,1 ≈ 0	r	z ≈	z ₁ ≈	
PM 4	4	3,2	6	1	10,5	8,5	0,64	0,3	0,5	0,5	0,002
PM 5	5	4	8	1,5	13	10,5	0,74	0,5	0,5	0,5	0,003
PM 6	6	5	9	1,5	15,5	12,5	0,74	0,5	0,5	0,75	0,004
PM 8	8	6	12	2	20	16,5	0,94	0,5	1	1	0,009
PM 10	10	8	14	2	25	20,5	1,05	0,5	1	1	0,017
PM 12	12	9	17	3	30	24,5	1,15	0,5	1,5	1,25	0,030
PM 14	14	10	19	3	33	27,5	1,25	1	1,5	1,5	0,048
PM 16	16	12	20	3	38,5	32,5	1,35	1	1,5	1,5	0,067
PM 20	20	17,5	26	4	46	40,5	1,8	1	2	1,5	0,125
PM 25	25	18	32	5	57	50,5	1,8	1	2	1,5	0,260

Perni con testa bombata (sferica) e molla

Pins with barrel head (spherical) and spring

Sigla Designation	Dimensioni mm Dimensions mm									Peso Weight ≈ Kg
	d h11	d ₁ h11	D h12	k js14	L +0,3	L ₁ +0,3	m +0,1	z ₁ ≈		
PMB 14	14	10	20	2,5	33	27,5	1,25	1,25	0,041	
PMB 16	16	12	20	3,5	38,5	32,5	1,35	1,5	0,062	
PMB 18	18	13	25	3,5	42	36,5	1,35	1,5	0,090	
PMB 20	20	17,5	28	4	46	40,5	1,80	1,5	0,121	
PMB 25	25	18	34	5,5	57	50,5	1,80	1,5	0,231	

Su richiesta, disponibili in acciaio inox ed alluminio
Under request, stainless steel and aluminium available

Perni per forcelle Pins for clevises

PS-PS..CN

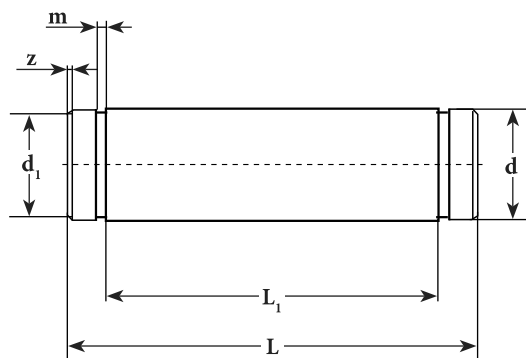

Sigla Designation	Dimensioni mm Dimensions mm						Peso Weight
	d h11	d ₁ h11	L +0,4 ≈ 0	L ₁ +0,3 ≈ 0	m H13	z ≈	≈ Kg
PS 5	5	4,8	15	10,5	0,7	1	0,003
PS 6	6	5,7	17	12,2	0,8	1	0,005
PS 8	8	7,6	20	16,5	0,9	1	0,008
PS 10	10	9,6	25	20,5	1,1	1	0,015
PS 12	12	12	30	24,5	1,1	1	0,026
PS 14	14	13	35	27,5	1,1	1	0,042
PS 16	16	15	39	32,5	1,1	1	0,061
PS 20	20	19	48	40,5	1,3	1	0,118
PS 25	25	24	60	50,5	1,3	1	0,230
PS 30	30	29	65	55,5	1,6	1	0,350
PS 35	35	33	84	70,5	1,6	1	0,620

Perni per forcelle ex CNomo Pins for ex CNomo clevises

Sigla Designation	Dimensioni mm Dimensions mm						Peso Weight
	d h11	d ₁ h11	L +0,4 ≈ 0	L ₁ +0,3 ≈ 0	m H13	z ≈	≈ Kg
PS 8 CN	8	7,6	30	22	0,9	1	0,012
PS 12 CN	12	11,5	45	36	1,1	1	0,039
PS 16 CN	16	15,2	55	45	1,1	1	0,085
PS 20 CN	20	19	75	63	1,3	1	0,185
PS 25 CN	25	23,9	95	80	1,3	1	0,360

Su richiesta, disponibili in acciaio inox
Under request, stainless steel available

Rondelle per perni Washers for pins

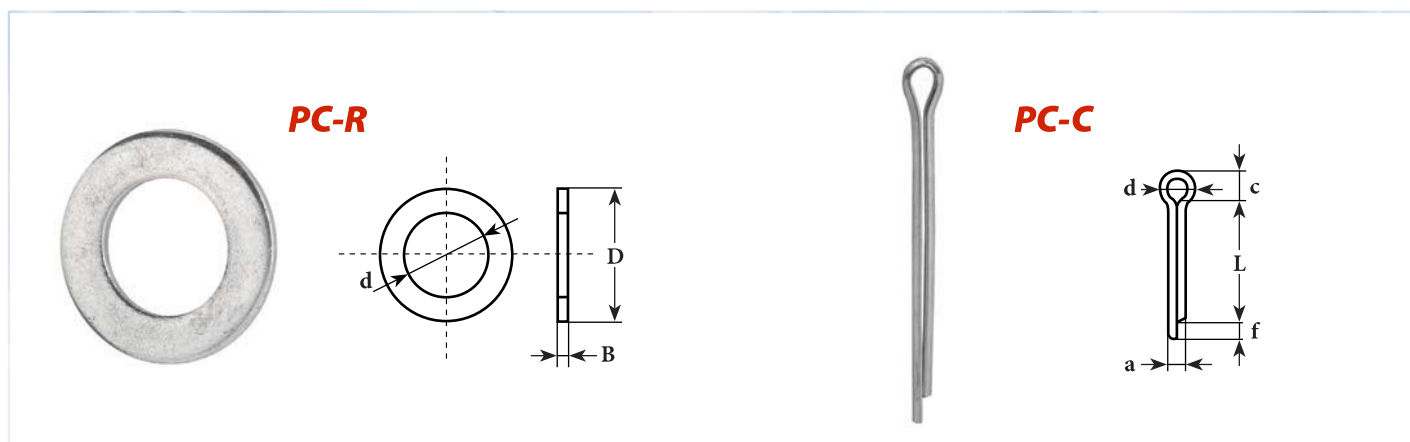

Sigla Designation	Dimensioni mm Dimensions mm			Peso ¹⁾ Weight ¹⁾
	d	D	B	≈ Kg
PC-R 4	4,3	7,5	0,8	0,15
PC-R 5	5,3	9,5	1	0,39
PC-R 6	6,4	11	1,6	0,70
PC-R 8	8,4	15	1,6	1,52
PC-R 10	10,5	18	1,6	2,11
PC-R 12	13	20	2	2,85
PC-R 14	15	24	2	4,30
PC-R 16	17	27	2	5,42
PC-R 20	21	33	2,5	9,98
PC-R 25	25	39	4	14,50

¹⁾ Peso riferito a 1.000 pezzi Weight ref. 1.000 pcs.

Copiglie per perni Split pins for pins

Sigla Designation	Dimensioni mm Dimensions mm				
	d	a	c	f	L
PC-C 4	1,5	1	2,5	1,5	10
PC-C 5/6	3,6	1,6	4	2,5	10
PC-C 8	5,8	2	6,4	3,2	16
PC-C 10	7,4	3,2	8	4	20
PC-C 12/16	7,4	4	8	4	32
PC-C 20/25	9,2	4	10	4	32

Su richiesta, disponibili in acciaio inox ed alluminio
Under request, stainless steel and aluminium available

Molle per perni

Safety clips



PM-S

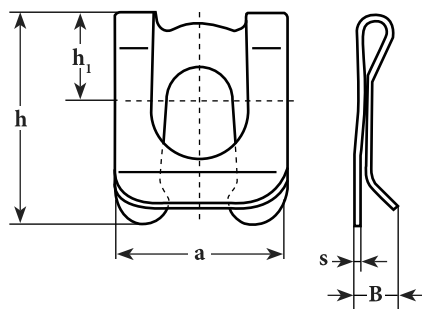

PM

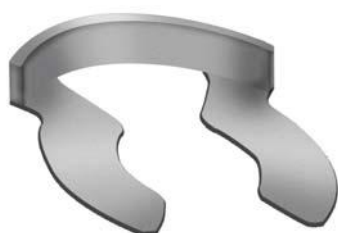
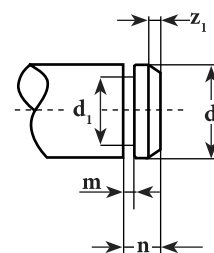

PM-K

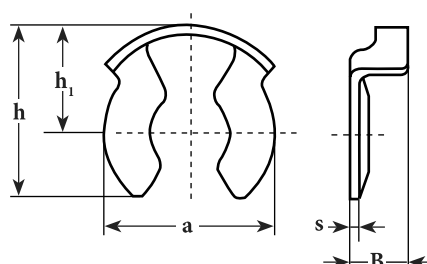

PM

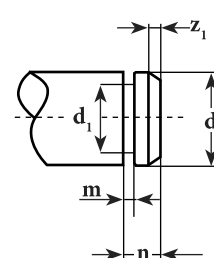

Sigla Designation	Dimensioni mm Dimensions mm										Forza assiale max Max strength (daN)
	d_{h11}	d_{1h11}	a_{\approx}	B	h_{\approx}	$h_{1\approx}$	$m_{+0,1\approx 0}$	$n_{+0,3\approx 0}$	s	$z_{1\approx}$	
PM-S 4	4	3,2	7	2,3	8,5	4	0,64	2	0,3	0,50	100
PM-S 5	5	4	9	3,3	10,7	5	0,74	2,5	0,4	0,50	130
PM-S 6	6	5	11	3,8	14,1	6	0,74	3	0,4	0,75	150
PM-S 8	8	6	14	4	17,5	8	0,94	3,5	0,5	1	360
PM-S 10	10	8	18	5	22,1	10	1,05	4,5	0,5	1	640
PM-S 12	12	9	22	5	26	12	1,15	5	0,5	1,25	960
PM-S 14	14	10	25	6	30	13,5	1,25	5,5	0,6	1,5	1.130
PM-S 16	16	12	28	6	34	16	1,35	6	0,6	1,5	1.350

Sigla Designation	Dimensioni mm Dimensions mm										Forza assiale max Max strength (daN)
	d_{h11}	d_{1h11}	a_{\approx}	B	h_{\approx}	$h_{1\approx}$	$m_{+0,1\approx 0}$	$n_{+0,3\approx 0}$	s	$z_{1\approx}$	
PM-K 4	4	3,2	6,5	2,7	7	4,3	0,64	2	0,4	0,50	150
PM-K 5	5	4	7,5	2,8	8,7	5,2	0,74	2,5	0,5	0,50	300
PM-K 6	6	5	10,4	3,5	11,5	6,8	0,74	3	0,5	0,75	485
PM-K 8	8	6	11,5	4,1	12,1	7,2	0,94	3,5	0,5	1	550
PM-K 10	10	8	15,6	5,9	16,3	9,5	1,05	4,5	0,6	1	950
PM-K 12	12	9	16,7	6,1	18	10,5	1,15	5	0,6	1,25	1.070
PM-K 14	14	10	19	6,5	20	11,5	1,25	5,5	0,7	1,5	1.270
PM-K 16	16	12	22,7	7,8	23,5	13,8	1,35	6	0,8	1,5	1.400
PM-K 20-25	20-25	16-18	34,5	9	34	20	1,8	8	1	1,5	1.600

Su richiesta, disponibili in acciaio inox ed alluminio
Under request, stainless steel and aluminium available

Seeger Snap rings

SE

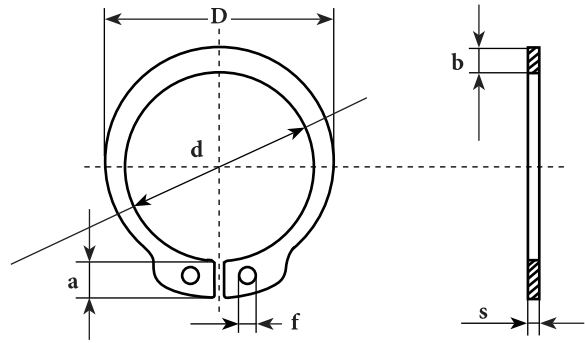

Sigla Designation	Dimensioni mm Dimensions mm					
	d	a	b _≈	D	f	s
SE 8	7,4	3,2	1,5	14,7	1,2	0,8
SE 10	9,3	3,3	1,8	17	1,5	1
SE 12	11	3,3	1,8	19	1,7	1
SE 14	12,9	3,5	2,1	21,4	1,7	1
SE 16	14,7	3,7	2,2	23,8	1,7	1
SE 20	18,5	4	2,6	28,4	2	1,2
SE 25	23,2	4,4	3	34,2	2	1,2
SE 30	27,9	5	3,5	40,5	2	1,5
SE 35	32,2	5,6	3,9	46,8	2,5	1,5

Su richiesta, disponibili in acciaio inox ed alluminio
Under request, stainless steel and aluminium available