

Corone per catene a rulli ISO

DIN 8188 – ISO 606

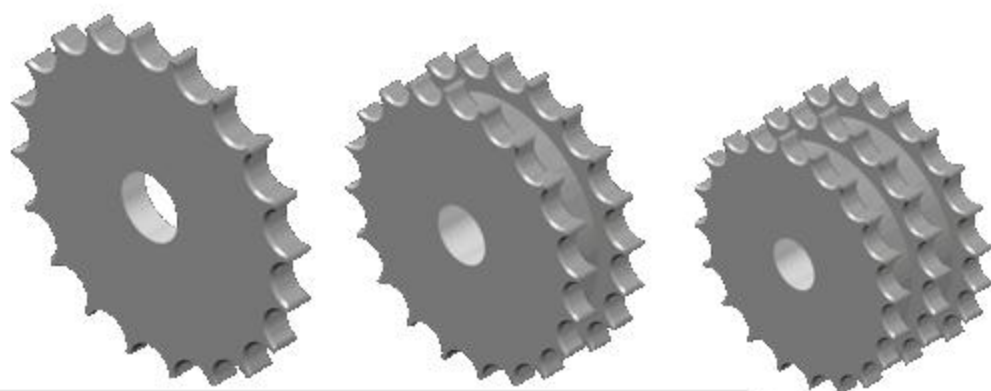

Catalogo tecnico 2009

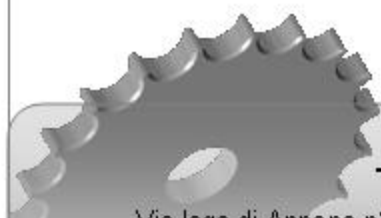

-Trasmissioni industriali s.a.s. -

Via lago di Annone n°15 36015 Schio VI - Italy – Tel: 0445-500142 fax: 0445-500018

Mail: info@trasmissioniindustriali.com Site web: www.trasmissioniindustriali.com



CORONE PER CATENE A RULLI - DIN 8187 - ISO 606

PLATE WHEELS FOR ROLLER CHAINS - DIN 8187 - ISO 606

5 x 2,5 mm

Rullo 3,2 mm

03 - 1

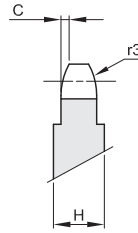
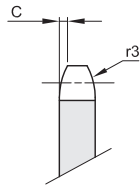

Da Z 51 H=4 mm

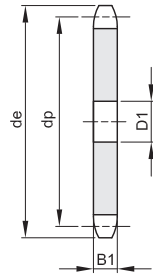

B1	B2	B3	b1	C	r3
2,3				0,4	5

Z	de	dp	semplici		doppie		triple		Z	de	dp	semplici		doppie		triple	
			D1	Kg.	D2	Kg.	D3	Kg.				D1	Kg.	D2	Kg.	D3	Kg.
8	14,8	13,06	4	0,01					51	83,0	81,22						
9	16,4	14,62	4	0,01					52	84,6	82,81	10	0,17				
10	17,9	16,18	4	0,01					53	86,2	84,40						
11	19,5	17,75	5	0,01					54	87,7	85,97	10	0,18				
12	21,1	19,32	5	0,01					55	89,3	87,58	10	0,19				
13	22,6	20,89	5	0,01					56	90,9	89,17	10	0,20				
14	24,2	22,47	5	0,01					57	92,6	90,76	10	0,20				
15	25,8	24,04	5	0,01					58	94,1	92,35	10	0,21				
16	27,4	25,63	6	0,01					59	95,7	93,94						
17	29,0	27,20	6	0,01					60	97,3	95,53	10	0,23				
18	30,5	28,79	6	0,01					62	100,5	98,72	12	0,24				
19	32,1	30,38	6	0,01					64	103,7	101,90						
20	33,7	31,96	6	0,01					65	105,2	103,49	12	0,27				
21	35,3	33,54	8	0,01					66	106,8	105,08	12	0,28				
22	36,9	35,13	8	0,02					68	110,0	108,26						
23	38,5	36,72	8	0,02					70	113,2	111,44	12	0,31				
24	40,1	38,30	8	0,02					72	116,4	114,63						
25	41,6	39,89	8	0,02					75	121,2	119,40	12	0,36				
26	43,2	41,48	8	0,02					76	122,7	120,99	12	0,37				
27	44,8	43,07	8	0,02					78	125,9	124,17						
28	46,4	44,65	8	0,03					80	129,1	127,35	12	0,41				
29	48,0	46,25							85	137,1	135,31	14	0,46				
30	49,6	47,83	8	0,03					90	145,0	143,27	14	0,52				
31	51,2	49,42							95	153,0	151,22	14	0,58				
32	52,8	51,01	8	0,03					100	160,9	159,18	14	0,65				
33	54,4	52,60	8	0,04					110	176,8	175,09	14	0,79				
34	55,9	54,19	8	0,04					114	183,2	181,46	14	0,85				
35	57,5	55,78	8	0,04					120	192,8	191,01	14	0,95				
36	59,1	57,37	8	0,04					125	200,7	198,96	14	1,03				
37	60,7	58,96	8	0,05													
38	62,3	60,54	8	0,05													
39	63,9	62,13															
40	65,5	63,73	8	0,05													
41	67,1	65,31															
42	68,7	66,91	8	0,06													
43	70,2	68,49															
44	71,8	70,09	8	0,07													
45	73,4	71,68	8	0,07													
46	75,0	73,27	8	0,07													
47	76,6	74,86															
48	78,2	76,45	8	0,08													
49	79,8	78,03															
50	81,4	79,63	8	0,08													



CORONE PER CATENE A RULLI - DIN 8187 - ISO 606
PLATE WHEELS FOR ROLLER CHAINS - DIN 8187 - ISO 606

6 x 2,8 mm

Rullo 4 mm

04 - 1

B1	B2	B3	b1	C	r3
2,6				0,6	6

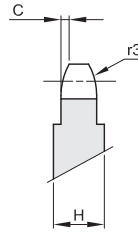
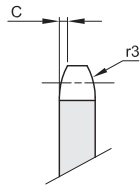

Da Z 51 H=4 mm

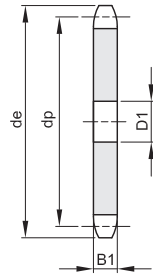

Z	de	dp	semplici		doppie		triple		Z	de	dp	semplici		doppie		triple	
			D1	Kg.	D2	Kg.	D3	Kg.				D1	Kg.	D2	Kg.	D3	Kg.
8	18,0	15,67	5	0,01					51	99,9	97,47						
9	19,9	17,54	5	0,01					52	101,8	99,37	12	0,25				
10	21,7	19,42	6	0,01					53	103,7	101,27						
11	23,6	21,30	6	0,01					54	105,6	103,17	12	0,26				
12	25,4	23,18	6	0,01					55	107,6	105,08	12	0,27				
13	27,3	25,05	8	0,01					56	109,5	107,00	12	0,28				
14	29,2	26,96	8	0,01					57	111,4	108,93	12	0,29				
15	31,1	28,86	8	0,01					58	113,3	110,82	12	0,30				
16	33,0	30,76	8	0,01					59	115,2	112,71						
17	35,0	32,65	8	0,01					60	117,5	114,62	12	0,33				
18	36,9	34,55	8	0,02					62	120,9	118,45	16	0,35				
19	38,8	36,44	8	0,02					64	124,7	122,27	16	0,37				
20	40,7	38,44	8	0,02					65	126,6	124,18	16	0,38				
21	42,6	40,25	8	0,02					66	128,5	126,09	16	0,40				
22	44,5	42,16	8	0,02					68	132,4	129,91						
23	46,4	44,06	8	0,03					70	136,2	133,73	16	0,45				
24	48,3	45,96	8	0,03					72	140,0	137,55						
25	50,2	47,87	8	0,03					75	145,7	143,28						
26	52,1	49,77	8	0,03					76	148,1	145,19	16	0,53				
27	54,0	51,67	8	0,04					78	151,5	149,01						
28	55,9	53,58	8	0,04					80	155,3	152,82	16	0,59				
29	57,8	55,50							85	164,8	162,37	16	0,67				
30	59,8	57,42	8	0,05					90	174,4	171,92	16	0,77				
31	61,7	59,31							95	183,9	181,47	16	0,85				
32	63,6	61,21	10	0,05					100	193,5	191,01	16	0,94				
33	65,5	63,11	10	0,06					110	211,6	210,11						
34	67,4	65,02	10	0,06					114	220,2	217,75	16	1,23				
35	69,3	66,93	10	0,07					120	231,7	229,20	16	1,37				
36	71,2	68,84	10	0,07					125	241,2	238,75	16	1,48				
37	73,1	70,75	10	0,07													
38	75,0	72,66	10	0,08													
39	76,9	74,56															
40	78,9	76,47	10	0,09													
41	80,8	78,38															
42	82,7	80,28	12	0,10													
43	84,7	82,19															
44	86,6	84,10															
45	88,5	86,01	12	0,11													
46	90,4	87,92	12	0,12													
47	92,3	89,83															
48	94,2	91,74	12	0,13													
49	96,1	93,64															
50	98,0	95,55	12	0,14													



CORONE PER CATENE A RULLI - DIN 8187 - ISO 606

PLATE WHEELS FOR ROLLER CHAINS - DIN 8187 - ISO 606

8 x 3,0 mm

Rullo 5 mm

05B - 1 - 2

B1	B2	B3	b1	C	r3
2,8	8,3		2,7	0,8	8

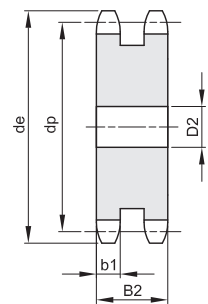
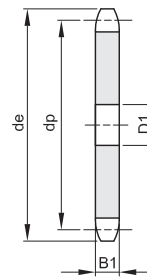
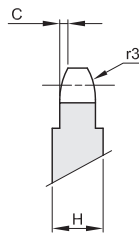
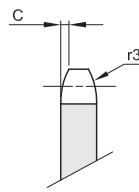

Da Z 46 H=4 mm

Z	de	dp	semplici D1 Kg.		doppie D2 Kg.		triple D3 Kg.		Z	de	dp	semplici D1 Kg.		doppie D2 Kg.		triple D3 Kg.	
8	23,4	20,90	6	0,01	8	0,01			51	134,0	129,95						
9	25,9	23,39	6	0,01	8	0,01			52	136,6	132,49	16	0,43	16	0,82		
10	28,4	25,89	8	0,01	8	0,02			53	139,1	135,04						
11	31,0	28,39	8	0,01	8	0,02			54	141,7	137,59	16	0,47				
12	33,7	30,91	8	0,01	8	0,03			55	144,2	140,13	16	0,49				
13	36,7	33,42	8	0,01	8	0,04			56	146,8	142,68			16	0,96		
14	39,2	35,95	8	0,02	8	0,05			57	149,3	145,22	16	0,53	16	0,99		
15	41,7	38,48	8	0,02	8	0,06			58	151,9	147,77	16	0,55				
16	44,2	41,01	8	0,02	10	0,07			59	154,5	150,31						
17	46,7	43,53	8	0,03	10	0,08			60	156,0	152,85	16	0,59	16	1,11		
18	49,2	46,07	8	0,03	10	0,09			62	162,2	157,95	16	0,63				
19	51,7	48,61	8	0,03	10	0,10			64	167,3	163,04	16	0,67				
20	54,2	51,14	8	0,04					65	169,8	165,58	16	0,69	20	1,30		
21	57,2	53,67	10	0,04	10	0,13			66	172,4	168,13						
22	59,4	56,21	10	0,05	10	0,14			68	177,5	173,22						
23	62,2	58,75	10	0,05	10	0,16			70	182,6	178,31	16	0,81				
24	64,7	61,29	10	0,06	10	0,17			72	187,7	183,41						
25	67,2	63,83	10	0,06	10	0,18			75	195,3	191,04	20	0,93				
26	69,7	66,37	10	0,07	12	0,18			76	196,7	193,59	20	0,94	20	1,80		
27	72,3	68,91	10	0,07					78	203,0	198,68						
28	74,7	71,45	10	0,08	12	0,22			80	208,1	203,77	20	1,01	20	2,00		
29	77,2	73,99	10	0,09					85	220,8	216,50	20	1,20				
30	80,2	76,53	10	0,09	12	0,25			90	233,6	229,23	20	1,35				
31	82,7	79,08	10	0,10					95	246,3	241,96	20	1,51				
32	85,2	81,61	10	0,11	12	0,29			100	259,1	254,68	20	1,68				
33	87,7	84,16	10	0,11					110	284,6	280,15						
34	90,2	86,70	10	0,12	12	0,34			114	294,8	290,33	20	2,20	20	4,15		
35	92,7	89,24	10	0,13	12	0,36			120	310,1	305,61	20	2,44				
36	95,2	91,79	10	0,13	12	0,38			125	322,8	318,34	20	2,65				
37	97,7	94,33	12	0,14													
38	100,2	96,88	12	0,15	12	0,42											
39	102,7	99,42	12	0,16													
40	105,2	101,97	12	0,17	12	0,47											
41	108,4	104,51															
42	111,0	107,05	12	0,28													
43	113,5	109,60															
44	116,1	112,14	12	0,31													
45	118,6	114,69	12	0,32													
46	121,2	117,23	12	0,34	16	0,63											
47	123,7	119,77															
48	125,5	122,32	12	0,37	16	0,69											
49	128,9	124,86															
50	131,5	127,41	12	0,40	16	0,75											

3/8" x 7/32"
9,525 x 5,72 mm
Rullo 6,35 mm
06B - 1 - 2 - 3

B1	B2	B3	b1	C	r3
5,3	15,4	25,6	5,2	1	10

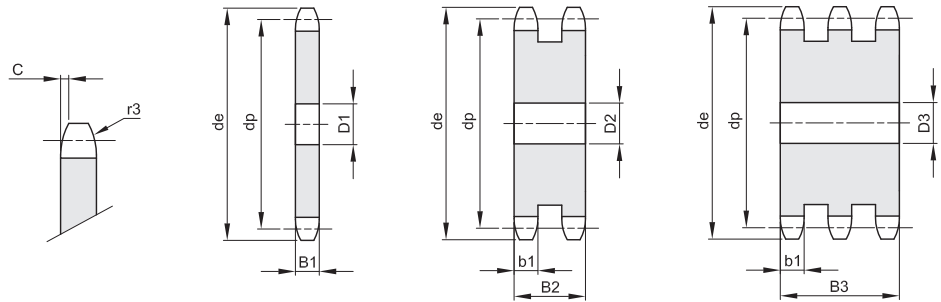

Z	de	dp	semplici		doppie		triple		Z	de	dp	semplici		doppie		triple	
			D1	Kg.	D2	Kg.	D3	Kg.				D1	Kg.	D2	Kg.	D3	Kg.
8	28,6	24,89	6	0,01	8	0,03	8	0,04	51	159,3	154,72	20	0,74	20	2,06		
9	31,5	27,85	8	0,02	8	0,04	8	0,06	52	162,4	157,75	20	0,77	20	2,15		
10	34,5	30,82	8	0,02	8	0,05	10	0,08	53	165,4	160,78	20	0,80	20	2,22		
11	37,5	33,80	8	0,03	10	0,06	12	0,09	54	168,4	163,82	20	0,83	20	2,33		
12	40,5	36,80	8	0,03	10	0,08	12	0,12	55	171,4	166,85	20	0,86	20	2,42		
13	43,5	39,80	8	0,04	10	0,10	12	0,15	56	174,5	169,88	20	0,89	20	2,51		
14	46,5	42,80	8	0,05	10	0,12	12	0,18	57	177,5	172,91	20	0,93	20	2,61	25	4,28
15	49,5	45,81	8	0,06	10	0,14	12	0,22	58	180,5	175,93	20	0,96	20	2,71	25	4,44
16	52,5	48,82	10	0,06	12	0,16	12	0,26	60	186,6	181,99	20	1,03	20	2,91	25	4,77
17	55,5	51,83	10	0,07	12	0,19	12	0,30	62	192,7	188,06	20	1,10	25	3,09		
18	58,6	54,85	10	0,08	12	0,21	12	0,35	64	198,7	194,12	20	1,18	25	3,30	25	5,46
19	61,6	57,87	10	0,09	12	0,24	12	0,39	65	201,8	197,15	20	1,21	25	3,41	25	5,64
20	64,6	60,89	10	0,10	12	0,27	12	0,44	66	204,8	200,18	20	1,25			25	5,83
21	67,6	63,91	10	0,12	12	0,30	16	0,48	68	210,8	206,24	20	1,33	25	3,75		
22	70,6	66,93	10	0,13	12	0,34	16	0,54	70	216,9	212,30	20	1,41	25	3,99	25	6,59
23	73,7	69,95	10	0,14	12	0,37	16	0,59	72	223,0	218,37	20	1,50	25	4,23	25	6,99
24	76,7	72,97	10	0,15	12	0,41	16	0,66	75	232,1	227,46	20	1,63	25	4,60		
25	79,7	76,00	10	0,17	12	0,45	16	0,72	76	235,1	230,49	20	1,67	25	4,73	25	7,83
26	82,7	79,02	10	0,18	16	0,48	16	0,79	78	241,2	236,55			25	4,99		
27	85,7	82,04	10	0,20	16	0,53	16	0,86	80	247,2	242,61	20	1,86	25	5,26	25	8,71
28	88,8	85,07	10	0,21	16	0,57	16	0,93	85	262,4	257,77	25	2,10	25	5,96	25	9,87
29	91,8	88,09	10	0,23	16	0,62	16	1,01	90	277,5	272,93	25	2,36	25	6,71	25	11,11
30	94,8	91,12	10	0,25	16	0,66	16	1,09	95	292,7	288,08	25	2,63	25	7,50	25	12,42
31	97,9	94,15	12	0,26	16	0,71	16	1,17	100	307,8	303,25	25	2,92	25	8,34	25	13,81
32	100,9	97,17	12	0,28	16	0,77	16	1,26	110	338,2	333,55	25	3,54	25	10,14		
33	103,9	100,20	12	0,30	16	0,82			114	350,3	345,68	25	3,81	25	10,90	25	18,06
34	106,9	103,23	12	0,32	16	0,87	16	1,44	120	368,5	363,86	25	4,23	25	12,11		
35	110,0	106,26	12	0,34	16	0,93	16	1,53	125	383,6	379,02	25	4,59	25	13,16	25	21,81
36	113,0	109,29	12	0,36	16	0,99	20	1,61									
37	116,0	112,32	12	0,38	16	1,05											
38	119,0	115,34	12	0,40	16	1,11	20	1,81									
39	122,1	118,37	12	0,43	16	1,18											
40	125,1	121,40	12	0,45	16	1,24	20	2,02									
41	129,0	124,43	16	0,47	20	1,30											
42	132,1	127,46	16	0,49	20	1,36	20	2,25									
43	135,1	130,49	16	0,52	20	1,44											
44	138,1	133,52	16	0,55	20	1,51	20	2,49									
45	141,1	136,54	16	0,57	20	1,58	20	2,61									
46	144,2	139,58	16	0,60	20	1,66											
47	147,2	142,61	16	0,63													
48	150,2	145,64	16	0,65	20	1,82	20	2,99									
49	153,3	148,66	16	0,68	20	1,90											
50	156,3	151,69	20	0,71	20	1,98	20	3,27									

1/2" x 1/8"
12,7 x 3,3 mm
 Rullo 7,75 mm
081 - 1

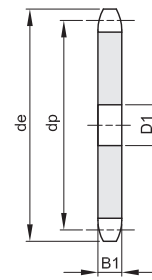
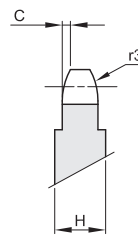
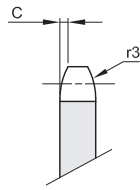

Da Z 31 H=4 mm
 Da Z 90 H=6 mm

B1	B2	B3	b1	C	r3
3				0,8	13

Z	de	dp	semplici D1 Kg.		doppie D2 Kg.		triple D3 Kg.		Z	de	dp	semplici D1 Kg.		doppie D2 Kg.		triple D3 Kg.	
8	39,5	33,18							51	213,1	206,30						
9	43,4	37,13	8	0,02					52	217,1	210,34						
10	47,4	41,10	8	0,02					53	221,2	214,87						
11	51,4	45,07	8	0,03					54	225,2	218,43						
12	55,4	49,07	8	0,04					55	229,3	222,46	20	1,25				
13	59,4	53,06	8	0,04					56	233,3	226,50	20	1,30				
14	63,4	57,07	8	0,05					57	237,3	230,54	20	1,35				
15	67,4	61,09	8	0,06					58	241,4	234,58						
16	71,4	65,10	8	0,07					59	245,4	238,62						
17	75,4	69,11	8	0,08					60	249,5	242,66	20	1,50				
18	79,4	73,14	8	0,09					62	257,5	250,75						
19	83,5	77,16	8	0,10					64	265,6	258,82						
20	87,5	81,19	8	0,11					65	269,7	262,86						
21	91,5	85,22	8	0,11					66	273,7	266,90						
22	95,5	89,24	10	0,13					68	281,8	274,99						
23	99,6	93,27	10	0,15					70	289,9	283,07	25	2,05				
24	103,6	97,29	12	0,16					72	298,0	291,16						
25	107,6	101,33	12	0,17					75	310,1	303,27						
26	111,7	105,36	12	0,26					76	314,1	307,33						
27	115,7	109,40	12	0,28					78	322,2	315,40						
28	119,7	113,42	12	0,32					80	330,3	323,48						
29	123,8	117,46							85	350,5	343,69						
30	127,8	121,50	12	0,35					90	370,7	363,90						
31	131,8	125,54							95	390,9	384,11						
32	135,9	129,56	12	0,40					100	411,1	404,31						
33	139,9	133,60	12	0,43					110	451,5	444,74						
34	143,9	137,64	12	0,46					114	467,7	460,90						
35	148,0	141,68	12	0,49					120	492,0	485,16						
36	152,0	145,72	16	0,51					125	512,2	505,37						
37	156,1	149,76	16	0,55													
38	160,1	153,80	16	0,58													
39	164,1	157,83	16	0,61													
40	168,2	161,87	16	0,64													
41	172,7	165,91															
42	176,7	169,95															
43	180,8	173,99															
44	184,8	178,03	16	0,79													
45	188,9	182,07	16	0,82													
46	192,9	186,10															
47	196,9	190,14															
48	201,0	194,18	20	0,94													
49	205,0	198,22															
50	209,1	202,26															



CORONE PER CATENE A RULLI - DIN 8187 - ISO 606

PLATE WHEELS FOR ROLLER CHAINS - DIN 8187 - ISO 606

1/2" x 3/16"
12,7 x 4,88 mm
Rullo 7,75 mm
083 - 1 / 084 - 1

B1	B2	B3	b1	C	r3
4,5				1,3	13

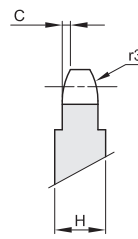
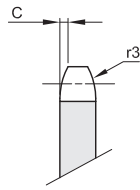

Da Z 90 H=6 mm

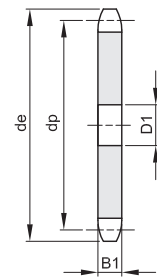

Z	de	dp	semplici		doppie		triple		Z	de	dp	semplici		doppie		triple	
			D1	Kg.	D2	Kg.	D3	Kg.				D1	Kg.	D2	Kg.	D3	Kg.
8	39,5	33,18	8	0,02					51	213,1	206,30	20	1,12				
9	43,4	37,13	8	0,03					52	217,1	210,34	20	1,17				
10	47,4	41,10	8	0,04					53	221,2	214,37	20	1,22				
11	51,4	45,07	8	0,05					54	225,2	218,43	20	1,26				
12	55,4	49,07	8	0,05					55	229,3	222,46	20	1,31				
13	59,4	53,06	8	0,06					56	233,3	226,50	20	1,36				
14	63,4	57,07	8	0,08					57	237,3	230,54	20	1,41				
15	67,4	61,09	8	0,09					58	241,4	234,58	20	1,46				
16	71,4	65,10	8	0,10					59	245,5	238,62						
17	75,4	69,11	8	0,12					60	249,5	242,66	20	1,57				
18	79,4	73,14	8	0,13					62	257,5	250,75						
19	83,5	77,16	8	0,15					64	265,6	258,82	20	1,80				
20	87,5	81,19	8	0,16					65	269,7	262,86	20	1,85				
21	91,5	85,22	8	0,18					66	273,7	266,90						
22	95,5	89,24	10	0,20					68	281,8	274,99	25	2,02				
23	99,6	93,27	10	0,22					70	289,9	283,07	25	2,14				
24	103,6	97,29	12	0,24					72	298,0	291,16	25	2,27				
25	107,6	101,33	12	0,26					75	310,1	303,27						
26	111,7	105,36	12	0,28					76	314,1	307,33	25	2,54				
27	115,7	109,40	12	0,30					78	322,2	315,40						
28	119,7	113,42	12	0,33					80	330,3	323,48	25	2,82				
29	123,8	117,46	12	0,35					85	350,5	343,69	25	3,19				
30	127,8	121,50	12	0,38					90	370,7	363,90						
31	131,8	125,54	12	0,40					95	390,9	384,11						
32	135,9	129,56	12	0,43					100	411,1	404,31	25	5,83				
33	139,9	133,60	12	0,46					110	451,5	444,74						
34	143,9	137,64	12	0,49					114	467,7	460,90						
35	148,0	141,68	12	0,52					120	492,0	485,16						
36	152,0	145,72	16	0,55					125	512,2	505,37						
37	156,1	149,76	16	0,58													
38	160,1	153,80	16	0,62													
39	164,1	157,83	16	0,65													
40	168,2	161,87	16	0,68													
41	172,7	165,91	16	0,72													
42	176,7	169,95	16	0,76													
43	180,8	173,99	16	0,80													
44	184,8	178,03	16	0,83													
45	188,9	182,07	16	0,87													
46	192,9	186,10	20	0,91													
47	196,9	190,14	20	0,95													
48	201,0	194,18	20	0,99													
49	205,0	198,22	20	1,04													
50	209,1	202,26	20	1,08													

1/2" x 5/16"
12,7 x 7,75 mm
Rullo 8,51 mm
08B - 1 - 2 - 3

B1	B2	B3	b1	C	r3
7,2	21	34,9	7	1,3	13

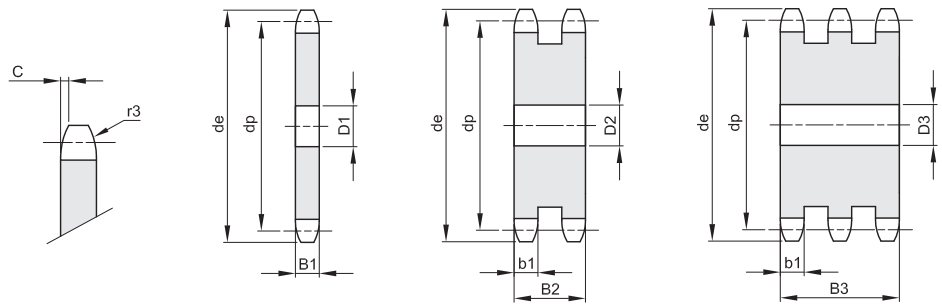

Z	de	dp	semplici		doppie		triple		Z	de	dp	semplici		doppie		triple	
			D1	Kg.	D2	Kg.	D3	Kg.				D1	Kg.	D2	Kg.	D3	Kg.
8	38,0	33,18	8	0,03	10	0,07	10	0,11	51	212,8	206,30	20	1,80	25	5,03		
9	42,0	37,13	8	0,04	10	0,10	10	0,16	52	216,9	210,34	20	1,87	25	5,24	25	8,68
10	45,9	41,10	8	0,06	10	0,13	10	0,21	53	220,9	214,37	20	1,94	25	5,46		
11	49,9	45,07	10	0,07	10	0,17	12	0,26	54	225,0	218,43	20	2,02	25	5,68	25	9,40
12	53,9	49,07	10	0,08	10	0,21	12	0,33	55	229,0	222,46	20	2,10	25	5,90	25	9,77
13	57,9	53,06	10	0,10	10	0,25	12	0,40	56	233,0	226,50	20	2,17	25	6,13	25	10,15
14	61,9	57,07	10	0,12	10	0,30	12	0,48	57	237,1	230,54	20	2,25	25	6,36	25	10,53
15	65,9	61,09	10	0,14	10	0,36	12	0,57	58	241,1	234,58	20	2,34	25	6,59		
16	69,9	65,10	10	0,16	12	0,41	16	0,64	59	245,2	238,62						
17	74,0	69,11	10	0,18	12	0,47	16	0,74	60	249,2	242,66	20	2,50	25	7,08	25	11,73
18	78,0	73,14	10	0,20	12	0,54	16	0,85	62	257,3	250,75	25	2,67	25	7,60	25	15,56
19	82,0	77,16	10	0,23	12	0,61	16	0,97	64	265,4	258,82	25	2,85	25	8,10		
20	86,0	81,19	10	0,26	12	0,68	16	1,09	65	269,4	262,86	25	2,94	25	8,36	25	13,86
21	90,1	85,22	12	0,28	16	0,75	16	1,22	66	273,4	266,90	25	3,03				
22	94,1	89,24	12	0,31	16	0,83	16	1,36	68	281,5	274,99	25	3,22	25	9,20	25	15,22
23	98,1	93,27	12	0,34	16	0,92	16	1,50	70	289,6	283,07	25	3,42	25	9,75	25	16,17
24	102,1	97,29	12	0,38	16	1,01	16	1,63	72	297,7	291,16	25	3,62	25	10,33	25	17,14
25	106,2	101,33	12	0,41	16	1,10	16	1,81	75	309,8	303,27	25	3,94	25	11,24	25	18,65
26	110,2	105,36	16	0,44	16	1,20	16	1,98	76	313,9	307,33	25	4,05	25	11,55	25	19,17
27	114,2	109,40	16	0,48	16	1,31	16	2,15	78	321,9	315,40	25	4,27				
28	118,3	113,42	16	0,52	16	1,42	16	2,33	80	330,0	323,48	25	4,50	25	12,90	25	21,82
29	122,3	117,46	16	0,56	16	1,53	16	2,52	85	350,2	343,69	25	5,62	25	14,55	25	24,15
30	126,3	121,50	16	0,60	16	1,65	16	2,71	90	370,4	363,90	25	6,31	25	16,36	25	27,17
31	130,4	125,54	16	0,64	16	1,77			95	390,7	384,11	25	7,05	25	18,28	25	30,36
32	134,4	129,56	16	0,68	16	1,90	20	3,09	100	410,9	404,31	25	7,82	25	20,30	25	33,73
33	138,4	133,60	16	0,73	16	2,02	20	3,30	110	451,3	444,74	25	9,50	25	24,67		
34	142,5	137,64	16	0,78	16	2,16	20	3,53	114	467,4	460,90	25	10,21	25	26,53	25	44,10
35	146,5	141,68	16	0,83	16	2,30	20	3,76	120	491,7	485,16	25	11,32	25	29,46		
36	150,6	145,72	16	0,88	20	2,42	20	3,99	125	511,0	505,37	25	12,31	25	32,00	25	55,21
37	154,6	149,76	16	0,93	20	2,56											
38	158,6	153,80	16	0,98	20	2,71	20	4,49									
39	162,7	157,83	16	1,03	20	2,87											
40	166,7	161,87	16	1,09	20	3,03	20	5,00									
41	172,4	165,91	20	1,14	20	3,20											
42	176,5	169,95	20	1,20	20	3,36	25	5,51									
43	180,5	173,99	20	1,26	20	3,53	25	5,80									
44	184,6	178,03	20	1,32	20	3,71	25	6,09									
45	188,6	182,07	20	1,38	20	3,89	25	6,39									
46	192,6	186,10	20	1,45	20	4,07	25	6,70									
47	196,7	190,14	20	1,51			25	7,00									
48	200,7	194,18	20	1,58	20	4,96	25	7,33									
49	204,8	198,22	20	1,65	20	4,66											
50	208,8	202,26	20	1,72	20	4,86	25	8,00									

5/8" x 3/8"

15,875 x 9,65 mm

Rullo 10,16 mm

10B - 1 - 2 - 3

B1	B2	B3	b1	C	r3
9,1	25,5	42,1	9	1,6	16

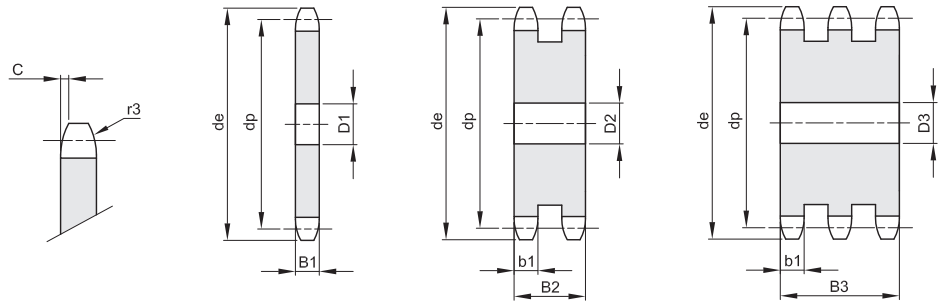

Z	de	dp	semplici		doppie		triple		Z	de	dp	semplici		doppie		triple	
			D1	Kg.	D2	Kg.	D3	Kg.				D1	Kg.	D2	Kg.	D3	Kg.
8	48,4	41,48	10	0,06	10	0,15	12	0,23	51	266,3	257,87	20	3,56				
9	53,3	46,42	10	0,09	10	0,21	12	0,32	52	271,3	262,92	20	3,70	25	10,11	25	16,57
10	58,3	51,37	10	0,11	10	0,27	12	0,44	53	276,4	267,97	20	3,85	25	10,52		
11	63,2	56,34	10	0,14	10	0,34	12	0,55	54	281,4	273,03	20	4,00	25	10,94		
12	68,2	61,34	10	0,17	10	0,42	12	0,67	55	286,5	278,08	20	4,15	25	11,36	25	18,62
13	73,2	66,32	10	0,20	10	0,51	12	0,81	56	291,5	283,13	25	4,30	25	11,80		
14	78,2	71,34	12	0,23	10	0,60	12	0,97	57	296,6	288,18	25	4,46	25	12,24	25	20,06
15	83,2	76,36	12	0,27	12	0,70	12	1,14	58	301,6	293,23	25	4,62	25	12,68		
16	88,3	81,37	12	0,31	12	0,82	16	1,29	60	311,7	303,32	25	4,95	25	13,61	25	22,31
17	93,3	86,39	12	0,36	12	0,94	16	1,49	62	321,8	313,43	25	5,30	25	14,56		
18	98,3	91,42	12	0,41	12	1,06	16	1,70	64	331,9	323,53	25	5,65			30	25,43
19	103,3	96,45	12	0,46	12	1,20	16	1,92	65	337,0	328,58	25	5,83	25	16,05	30	26,26
20	108,4	101,49	12	0,51	12	1,34	16	2,15	66	342,0	333,63			25	16,57		
21	113,4	106,52	12	0,57	16	1,48	16	2,40	68	352,1	343,74	25	6,40				
22	118,4	111,55	12	0,62	16	1,64	16	2,66	70	362,2	353,84	25	6,79	25	18,70	30	30,61
23	123,5	116,58	12	0,69	16	1,80	16	2,94	72	372,3	363,95	25	7,19	25	19,81		
24	128,5	121,62	12	0,75	16	1,98	16	3,23	75	387,5	379,09	25	7,81	25	21,54	30	30,35
25	133,6	126,66	12	0,82	16	2,17	16	3,53	76	392,5	384,16	25	8,02	25	22,14	30	36,27
26	138,6	131,70	16	0,88	20	2,33	20	3,81	78	402,6	394,25	25	8,46				
27	143,6	136,75	16	0,95	20	2,53	20	4,13	80	412,7	404,35	25	8,91	25	24,60	30	40,30
28	148,7	141,78	16	1,03	20	2,74	20	4,47	85	438,0	429,62	30	10,06	30	28,00		
29	153,7	146,83	16	1,11	20	2,96	20	4,83	90	463,3	454,88	30	11,30	30	31,25	30	51,32
30	158,8	151,87	16	1,19	20	3,18	20	5,20	95	488,5	480,14	30	12,61	30	34,90	30	57,32
31	163,8	156,92	16	1,28	20	3,41			100	513,8	505,40	30	13,99	30	38,75		
32	168,9	161,95	16	1,36	20	3,66	20	5,97	110	564,3	555,92	30	17,00				
33	173,9	167,00	16	1,45	20	3,90	20	6,38	114	584,5	576,13	30	19,99	30	50,60	30	83,15
34	178,9	172,05	16	1,55	20	4,16	20	6,80	120	614,8	606,44	30	22,17	30	56,16		
35	184,0	177,10	16	1,64	20	4,42	20	7,23	125	640,1	631,71	30	24,08	30	61,00	30	100,29
36	189,0	182,15	20	1,73	20	4,70	25	7,62									
37	194,1	187,20	20	1,83	20	4,98	25	8,08									
38	199,1	192,24	20	1,94	20	5,26	25	8,55									
39	204,2	197,29	20	2,05	20	5,56	25	9,04									
40	209,2	202,34	20	2,16	20	5,87	25	9,54									
41	215,8	207,39	20	2,29			25	10,05									
42	220,8	212,44	20	2,39	25	6,46	25	10,58									
43	225,9	217,49	20	2,50	25	6,80											
44	230,9	222,53	20	2,63	25	7,13	25	11,67									
45	236,0	227,58	20	2,75	25	7,47	25	12,24									
46	241,0	236,63	20	2,88	25	7,83	25	12,82									
47	246,1	237,68	20	3,01	25	8,19											
48	251,1	242,73	20	3,14	25	8,55	25	14,01									
49	256,2	247,78	20	3,28													
50	261,2	252,82	20	3,42	25	9,32	25	15,26									

3/4" x 7/16"

19,05 x 11,68 mm
Rullo 12,07 mm
12B - 1 - 2 - 3

B1	B2	B3	b1	C	r3
11,1	30,3	49,8	10,8	2	19

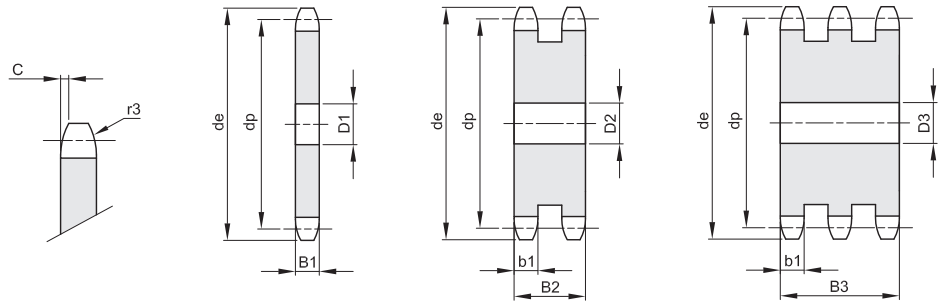

Z	de	dp	semplici		doppie		triple		Z	de	dp	semplici		doppie		triple	
			D1	Kg.	D2	Kg.	D3	Kg.				D1	Kg.	D2	Kg.	D3	Kg.
8	58,0	49,78	10	0,12	12	0,26	12	0,31	51	319,5	309,45	25	6,25				
9	63,9	55,70	10	0,15	12	0,36	12	0,57	52	325,6	315,50	25	6,50	25	17,31	25	28,40
10	69,8	61,64	10	0,20	12	0,46	12	0,74	53	331,6	321,56	25	6,77				
11	75,8	67,61	12	0,24	12	0,59	16	0,91	54	337,7	327,64	25	7,03	25	18,73	25	30,72
12	81,8	73,50	14	0,30	14	0,72	16	1,13	55	343,8	333,70	25	7,30	25	19,45	25	31,91
13	87,8	79,59	14	0,35	14	0,88	16	1,38	56	349,8	339,75	25	7,57	25	20,20		
14	93,8	85,61	14	0,41	16	1,02	16	1,64	57	355,9	345,81	25	7,85	25	20,95	30	34,28
15	99,8	91,63	14	0,48	16	1,20	16	1,93	58	362,0	351,87	25	8,13	25	21,72		
16	105,8	97,65	14	0,55	16	1,39	20	2,20	60	374,1	363,99	25	8,72	25	23,30	30	38,12
17	111,9	103,67	14	0,63	16	1,60	20	2,54	62	386,2	376,12	25	9,33				
18	117,9	109,71	14	0,71	16	1,81	20	2,89	64	398,3	388,24	25	9,95	30	26,62		
19	123,9	115,75	14	0,80	16	2,05	20	3,27	65	404,4	394,29	25	10,27	30	27,48	30	45,00
20	130,0	121,78	14	0,89	16	2,30	20	3,67	68	422,6	412,49	30	11,24				
21	136,0	127,82	16	0,99	20	2,53	20	4,10	70	434,7	424,61	30	11,92	30	32,01	30	52,42
22	142,0	133,86	16	1,03	20	2,80	20	4,55	72	446,8	436,74	30	12,63	30	33,92	30	55,55
23	148,1	139,90	16	1,20	20	3,09	20	5,02	75	465,0	454,91	30	13,72	30	36,88		
24	154,1	145,94	16	1,31	20	3,39	20	5,51	76	471,1	460,99	30	14,09	30	37,90	30	62,09
25	160,2	152,00	16	1,43	20	3,70	20	6,02	78	483,2	473,10	30	14,86				
26	166,2	158,04	16	1,56	20	4,03	20	6,56	80	495,3	485,22	30	15,65	30	42,10	30	68,98
27	172,3	164,09	16	1,68	20	4,38	20	7,12	85	525,6	515,55	30	17,70	30	47,66	30	78,10
28	178,3	170,13	16	1,82	20	4,73	20	7,71	90	555,9	545,86	30	19,87	30	53,36	30	87,79
29	184,4	176,19	16	1,96	20	5,10	20	8,31	95	586,2	576,17	30	22,18	30	59,80	30	98,04
30	190,4	182,25	16	2,10	20	5,49	20	8,97	100	616,6	606,47	30	24,60	30	66,39	30	108,86
31	196,5	188,31	20	2,24	20	5,88	25	9,52	110	677,2	667,11	30	29,84				
32	202,5	194,35	20	2,39	20	6,30	25	10,19	114	701,4	691,36	30	32,07	30	86,68	30	142,15
33	208,6	200,40	20	2,55	20	6,72	25	10,89	120	737,8	727,74	30	35,58			30	157,77
34	214,6	206,46	20	2,71	20	7,16	25	11,61	125	768,1	758,05	30	38,63	30	104,50	30	171,41
35	220,7	212,52	20	2,88	20	7,61	25	12,35									
36	226,8	218,58	20	3,06	25	7,99	25	13,11									
37	232,8	224,64	20	3,24	25	8,47	25	13,90									
38	238,9	230,69	20	3,42	25	8,96	25	14,70									
39	244,9	236,75	20	3,61	25	9,50	25	15,54									
40	251,0	242,81	20	3,80	25	9,99	25	16,40									
41	258,9	248,87	25	3,98	25	10,51											
42	265,0	254,93	25	4,19	25	11,07	25	18,17									
43	271,1	260,98	25	4,38	25	11,63	25	19,09									
44	277,1	267,03	25	4,61	25	12,21	25	20,03									
45	283,2	273,10	25	4,83	25	12,80	25	21,00									
46	289,2	279,16	25	5,05	25	13,40											
47	295,3	285,21	25	5,28	25	14,02	25	23,00									
48	301,4	291,27	25	5,52	25	14,65	25	24,04									
49	307,4	297,33	25	5,76													
50	313,5	303,39	25	6,00	25	15,95	25	26,17									

1" x 17,02 mm

25,4 x 17,02 mm

Rullo 15,88 mm

16B - 1 - 2 - 3

B1	B2	B3	b1	C	r3
16,2	47,7	79,6	15,8	2,5	26

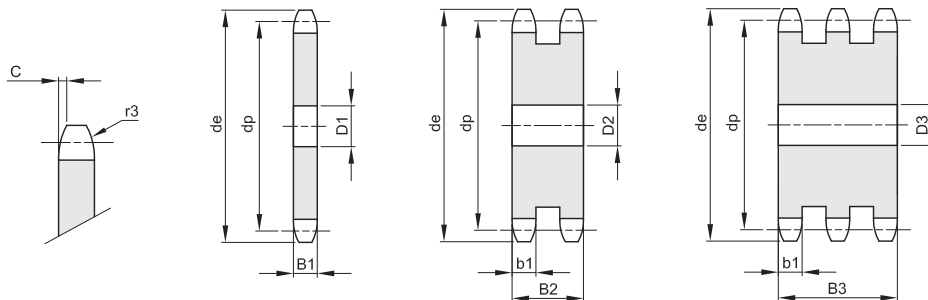

Z	de	dp	semplici		doppie		triple		Z	de	dp	semplici		doppie		triple	
			D1	Kg.	D2	Kg.	D3	Kg.				D1	Kg.	D2	Kg.	D3	Kg.
8	77,9	66,37	16	0,30	16	0,71	16	1,13	51	426,4	412,60	30	16,25				
9	85,8	74,27	16	0,39	16	0,97	16	1,56	52	434,5	420,67	30	16,90	30	48,40	40	79,98
10	93,8	82,19	16	0,51	16	1,27	16	2,05	53	442,5	428,75	30	17,58				
11	101,7	90,14	16	0,63	20	1,57	20	2,53	54	450,6	436,85	30	18,26				
12	109,7	98,14	16	0,77	20	1,94	20	3,15	55	458,7	444,93	30	18,96	30	54,38	40	89,92
13	117,7	106,12	16	0,92	20	2,36	20	3,84	56	466,8	453,01	30	19,67	40	56,24		
14	125,7	114,15	16	1,08	20	2,81	20	4,59	57	474,9	461,07	30	20,50	40	58,35	40	96,87
15	133,7	122,17	16	1,26	20	3,31	20	5,40	58	482,9	469,16	30	21,13				
16	141,8	130,20	20	1,43	20	3,84	25	6,16	60	499,1	485,32	30	22,65	40	64,90	40	107,78
17	149,8	138,22	20	1,64	20	4,41	25	7,11	62	515,3	501,50	30	24,22	40	69,46		
18	157,8	146,28	20	1,85	20	5,01	25	8,11	64	531,4	517,65	30	25,84				
19	165,9	154,33	20	2,08	20	5,66	25	9,18	65	539,5	525,73	30	26,67	40	76,59	40	127,24
20	173,9	162,38	20	2,32	20	6,34	25	10,31	68	563,8	549,98	30	29,23	40	84,07		
21	182,0	170,43	20	2,58	25	7,00	25	11,51	70	579,9	566,14	30	31,01	40	89,24	40	148,31
22	190,1	178,48	20	2,84	25	7,76	25	12,77	72	596,1	582,32	30	32,84	40	94,60	40	157,18
23	198,1	186,53	20	3,13	25	8,56	25	14,10	75	620,3	606,55	30	35,68	40	102,85		
24	206,2	194,59	20	3,42	25	9,40	25	14,49	76	628,4	614,65	30	36,65	40	105,69	40	175,70
25	214,2	202,66	20	3,73	25	10,28	25	16,94	78	644,6	630,80	30	38,64				
26	222,3	210,72	20	4,05	25	11,20	30	18,33	80	660,7	646,96	30	40,68	40	117,43	40	195,25
27	230,4	218,79	20	4,38	25	12,15	30	19,91	85	701,2	687,40	30	46,00	40	132,96	40	221,13
28	238,4	226,85	20	4,73	25	13,14	30	21,55	90	741,6	727,81	30	51,65	40	149,46	40	248,61
29	246,5	234,92	20	5,09	25	14,17	30	23,26	95	782,0	768,22	30	57,62	40	166,91	40	277,70
30	254,6	243,00	20	5,46	25	15,24	30	25,04	100	822,4	808,63	30	63,62	40	181,33		
31	262,6	251,08	25	5,82	25	16,35	30	26,88	110	903,3	889,48	30	77,50				
32	270,7	259,13	25	6,22	25	17,50	30	28,78	114	935,6	921,82	30	83,31	40	242,01	40	402,85
33	278,8	267,21	25	6,63	25	18,68	30	30,75	120	984,1	970,33	30	92,40				
34	286,9	275,28	25	7,06	25	19,90	30	32,78	125	1024,5	1010,73	30	100,33	40	291,84	40	485,90
35	294,9	283,36	25	7,50	25	21,16	30	34,88									
36	303,0	291,44	25	7,95	25	22,46	30	37,04									
37	311,1	299,51	25	8,41	25	23,80											
38	319,2	307,59	25	8,88	25	25,18	30	41,56									
39	327,2	315,67	25	9,37	25	26,59											
40	335,3	323,73	25	9,88	25	28,04	30	46,42									
41	345,6	331,82	25	10,39													
42	353,7	339,90	25	10,92	25	31,07	30	51,34									
43	361,7	347,98	25	11,46													
44	369,8	356,06	25	12,02	25	34,24	30	56,63									
45	377,9	364,12	25	12,60	25	35,89	30	59,36									
46	386,0	372,21	25	13,17	25	37,56	30	62,17									
47	394,1	380,29	25	13,76													
48	402,1	388,36	25	14,37	25	41,06	30	67,97									
49	410,2	396,44	25	14,99													
50	418,3	404,52	25	15,63	25	44,70	30	74,01									

1"1/4 x 3/4"

31,75 x 19,56 mm
Rullo 19,05 mm
20B - 1 - 2 - 3

B1	B2	B3	b1	C	r3
18,5	54,6	91	18,2	3,5	32

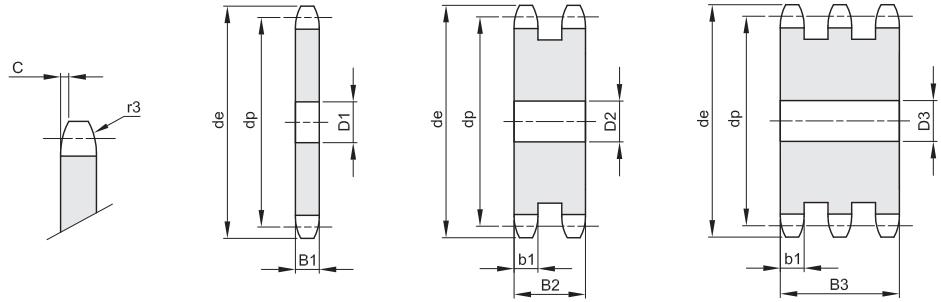

Z	de	dp	semplici		doppie		triple	
			D1	Kg.	D2	Kg.	D3	Kg.
8	96,0	82,96	16	0,55	20	1,28	20	2,02
9	106,5	92,84	16	0,73	20	1,74	20	2,79
10	117,0	102,74	16	0,93	20	2,28	20	3,77
11	127,0	112,68	20	1,13	20	2,89	25	4,53
12	137,0	122,68	20	1,38	20	3,56	25	5,64
13	147,5	132,65	20	1,65	20	4,31	25	4,87
14	157,6	142,68	20	1,94	20	5,12	25	8,20
15	167,7	152,72	20	2,26	20	6,00	25	9,65
16	177,7	162,75	20	2,60	30	6,78	30	11,07
17	187,7	172,78	20	2,96	30	7,80	30	12,75
18	197,8	182,85	20	3,34	30	8,89	30	14,54
19	207,9	192,91	20	3,75	30	10,05	30	16,45
20	217,9	202,98	20	4,19	30	11,27	30	18,47
21	228,0	213,04	25	4,62	30	12,56	30	20,62
22	238,1	223,11	25	5,09	30	13,93	30	22,87
23	248,2	233,17	25	5,60	30	15,36	30	25,24
24	258,3	243,23	25	6,18	30	16,86	30	27,72
25	268,4	253,33	25	6,67	30	18,43	30	30,32
26	278,4	263,40	30	7,21	30	20,07	30	33,03
27	288,5	273,48	30	7,81	30	21,17	30	35,86
28	298,5	283,56	30	8,43	30	23,56	30	38,80
29	308,6	293,65	30	9,07	30	25,39		
30	318,7	303,75	30	9,73	30	27,30	30	45,03
31	328,8	313,85	30	10,42	30	29,29		
32	338,9	323,91	30	11,13	30	31,34	30	51,72
33	349,0	334,01	30	11,87				
34	359,1	344,10	30	12,63	30	35,64	30	58,86
35	369,2	354,20	30	13,41	30	37,90	30	62,60
36	379,2	364,30	30	14,22	30	40,22	30	66,46
37	389,3	374,39	30	15,04				
38	399,4	384,49	30	15,90	30	45,08	30	74,52
39	409,5	394,59	30	16,77				
40	419,6	404,66	30	17,67	30	50,21	30	83,04
41	430,7	414,78	30	18,59				
42	440,8	424,88	30	19,54	30	55,62		
43	450,9	434,97	30	20,50				
44	461,0	445,07	30	21,50				
45	471,1	455,17	30	22,51	30	64,25	40	105,96
46	481,2	465,26	30	23,55	30	67,26		
48	501,4	485,46	30	25,70	30	73,49		
50	521,6	505,65	30	27,93	30	80,00	40	132,13
52	541,8	525,84	30	30,27	40	86,55		
54	562,0	546,07	30	32,69				

Z	de	dp	semplici		doppie		triple	
			D1	Kg.	D2	Kg.	D3	Kg.
55	572,1	556,16	30	33,94			40	161,16
56	582,2	566,26	30	35,21				
57	592,3	576,36	30	36,51	40	104,71	40	173,58
58	602,4	586,45	30	37,82				
60	622,6	606,65	30	40,53	40	116,43	40	193,06
64	663,0	647,06	30	46,22				
65	673,1	657,16	30	47,70	40	137,34	40	227,83
70	723,6	707,67	30	55,45	40	159,97	40	265,46
75	774,2	758,19	30	63,79				
76	784,3	768,32	30	66,53	40	189,39	40	314,39
80	824,7	808,72	30	72,71	40	210,38		
85	875,2	859,25	30	82,21				
90	925,7	909,76	30	92,30				
95	976,2	960,28	30	102,96	40	298,90		
100	1026,7	1010,79	40	114,13				
114	1168,2	1152,26	40	148,73	40	433,24	40	720,16

1"1/2 x 1"

38,1 x 25,4 mm
Rullo 25,4 mm
24B - 1 - 2 - 3

B1	B2	B3	b1	C	r3
24,1	72	120,3	23,6	4	38

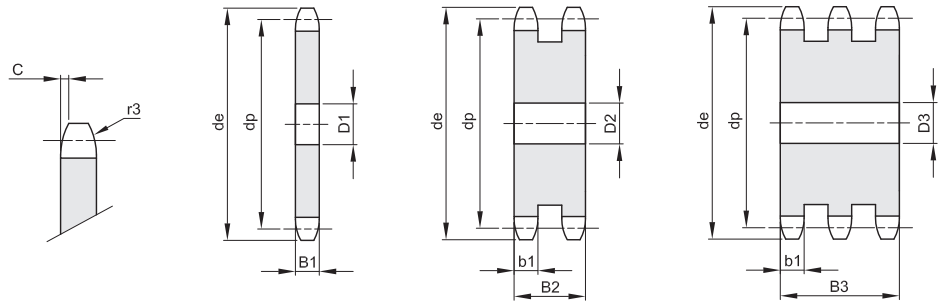

Z	de	dp	semplici		doppie		triple		Z	de	dp	semplici		doppie		triple	
			D1	Kg.	D2	Kg.	D3	Kg.				D1	Kg.	D2	Kg.	D3	Kg.
8	113,0	99,55	20	1,00	25	2,31	25	3,67	60	745,0	727,97	30	75,82	40	220,55	40	366,97
9	125,0	111,40	20	1,32	25	3,18	25	5,10	62	769,0	752,24	40	80,95				
10	137,0	123,29	20	1,69	25	4,19	25	6,75	65	805,5	788,59	40	89,14	40	260,19		
11	149,0	135,21	25	2,07	25	5,33	30	8,42	70	866,0	849,21	40	103,77				
12	161,0	147,22	25	2,53	25	6,59	30	10,50	76	939,0	921,98	40	122,54	40	358,88	40	597,76
13	173,0	159,18	25	3,03	25	7,99	30	12,81	80	987,5	970,44	40	135,99				
14	185,0	171,22	25	3,57	25	9,52	30	15,33	85	1048,0	1031,10	40	153,79				
15	197,0	183,26	25	4,16	25	11,18	30	18,08	95	1169,0	1152,33	40	192,67	40	583,00		
16	209,0	195,30	25	4,79	30	12,85	30	21,04									
17	221,0	207,34	25	5,47	30	14,77	30	24,22									
18	233,0	219,42	25	6,19	30	16,82	30	27,61									
19	245,5	231,49	25	6,95	30	19,00	30	31,23									
20	257,5	243,57	25	7,76	30	21,31	30	35,06									
21	270,5	255,65	30	8,57	30	23,75	40	38,60									
22	282,5	267,73	30	9,46	30	26,33	40	42,87									
23	294,5	279,80	30	10,40	30	29,03	40	47,36									
24	307,0	291,88	30	11,38	30	31,86	40	52,07									
25	319,0	304,00	30	12,41	30	34,83	40	56,99									
26	331,0	316,08	30	13,47	30	37,93	40	62,14									
27	343,0	328,19	30	14,59	30	41,15	40	67,50									
28	355,0	340,27	30	15,74	30	44,51	40	73,08									
29	367,5	352,38	30	16,94	30	48,00											
30	379,5	364,50	30	18,91	30	51,61	40	84,90									
31	391,5	376,62	30	19,47	40	55,05											
32	403,5	388,69	30	20,80	40	58,93	40	97,59									
33	415,5	400,81	30	22,18	40	62,94											
34	428,0	412,93	30	23,60	40	67,08											
35	440,0	425,04	30	25,06	40	71,35	40	118,26									
36	452,0	437,16	30	26,60	40	75,75											
37	464,0	449,27	30	28,12	40	80,28											
38	476,5	461,39	30	29,71	40	84,95	40	140,90									
40	501,5	485,62	30	33,03	40	94,66	40	158,08									
41	513,5	497,74	30	34,75													
42	525,5	509,85	30	36,52	40	104,90											
45	562,0	546,20	30	42,08	40	121,24	40	201,37									
46	574,0	558,32	30	44,03													
48	598,5	582,55	30	48,04	40	138,75	40	230,56									
50	622,5	606,78	30	52,24	40	151,08	40	251,11									
52	647,0	631,01	30	56,60													
54	671,0	655,25	30	61,14													
55	683,5	667,40	30	63,48													
56	695,5	679,50	30	65,86													
57	707,5	691,63	30	68,28	40	198,34	40	329,92									

CORONE PER CATENE A RULLI - DIN 8187 - ISO 606

PLATE WHEELS FOR ROLLER CHAINS - DIN 8187 - ISO 606

1"3/4 x 1"1/4

44,45 x 30,99 mm

Rullo 27,94 mm

28B - 1 - 2 - 3

B1	B2	B3	b1	C	r3
29,4	88,4	148	28,8	5	44

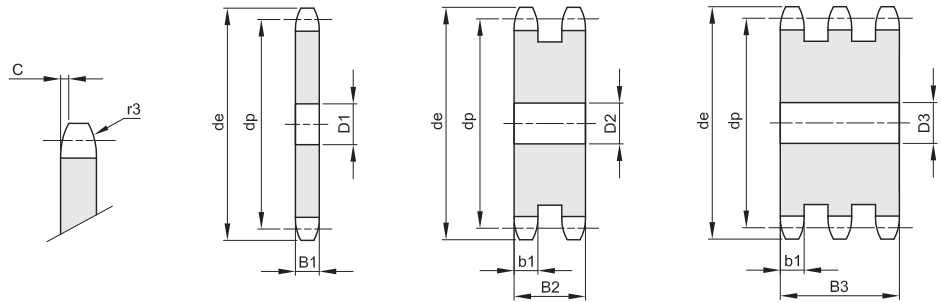

Z	de	dp	semplici		doppie		triple	
			D1	Kg.	D2	Kg.	D3	Kg.
8	132,0	116,15	20	1,71	25	4,01	25	6,39
9	146,0	129,96	20	2,26	25	5,48	25	8,80
10	160,0	143,85	20	2,88	25	7,17	25	11,56
11	174,0	157,77	25	3,53	30	8,92	30	14,44
12	188,0	171,74	25	4,29	30	11,04	30	17,93
13	204,0	185,75	25	5,12	30	13,38	30	21,79
14	218,0	199,76	25	6,03	30	15,94	30	26,02
15	232,0	213,79	25	7,01	30	18,72	30	30,61
16	246,0	227,84	30	8,02	30	21,71	30	35,57
17	260,0	241,90	30	9,14	30	24,92	30	40,89
18	274,0	255,98	30	10,34	30	28,36	30	46,58
19	289,0	270,06	30	11,61	30	32,00	30	52,64
20	303,0	284,15	30	12,95	30	35,87	30	59,06
21	317,0	298,24	30	14,37	30	39,96	40	65,20
22	331,0	312,34	30	15,86	30	44,26		
23	345,0	326,44	30	17,42	30	48,78	40	79,87
24	359,0	340,55	30	19,05				
25	373,0	354,66	30	20,76	30	58,50	40	95,99
26	387,0	368,77	30	22,54	40	63,28		
27	401,0	382,88	30	24,39				
28	416,0	397,00	30	26,32	40	74,29		
30	444,0	425,24	30	30,38	40	86,17	40	142,70
32	472,0	453,49	30	34,74				
34	500,0	481,75	30	39,38				
35	514,0	495,88	30	41,82	40	119,69		
36	529,0	510,01	30	44,32				
38	557,0	538,27	30	49,55	40	142,42	40	236,43
40	585,0	566,54	30	55,07	40	158,67	40	263,52
45	656,0	637,22	30	70,13	40	203,10	40	337,73
50	726,0	707,91	30	87,01	40	252,99		
57	825,0	806,90	40	113,56	40	332,00	40	552,76
60	869,0	849,32	40	126,08				
76	1095,0	1075,62	40	203,89	40	600,35	40	1000,97

Z	de	dp	semplici		doppie		triple	
			D1	Kg.	D2	Kg.	D3	Kg.



CORONE PER CATENE A RULLI - DIN 8187 - ISO 606

PLATE WHEELS FOR ROLLER CHAINS - DIN 8187 - ISO 606

2" x 1"1/4
50,8 x 30,99 mm
 Rullo 29,21 mm
32B - 1 - 2 - 3

B1	B2	B3	b1	C	r3
29,4	87,4	146	28,8	6	51

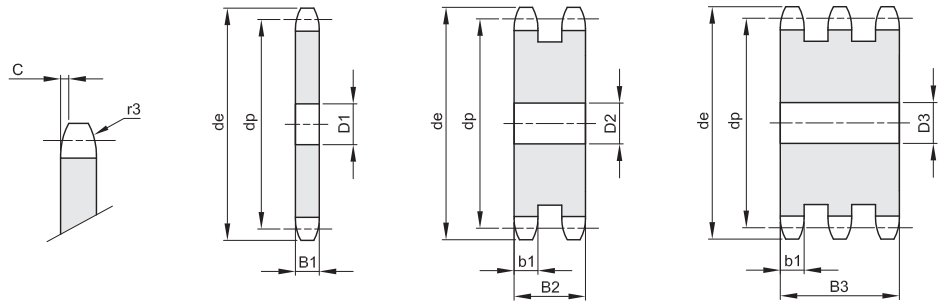

Z	de	dp	semplici		doppie		triple	
			D1	Kg.	D2	Kg.	D3	Kg.
8	152,0	132,74	25	2,27	25	5,53	25	8,83
9	168,0	148,54	25	2,99	25	7,46	25	11,99
10	184,0	164,39	25	3,81	25	9,68	25	15,63
11	200,0	180,31	30	4,67	35	11,86	35	19,20
12	216,0	196,29	30	5,67	35	14,64	35	23,78
13	235,0	212,29	30	6,77	35	17,70	35	28,83
14	251,0	228,29	30	7,97	35	21,05	35	34,35
15	267,0	244,30	30	9,26	35	24,68	35	40,34
16	283,0	260,40	30	10,64	40	28,38	40	46,47
17	299,0	276,46	30	12,12	40	32,57	40	53,40
18	315,0	292,55	30	13,69	40	37,05	40	60,80
19	331,0	308,66	30	15,36	40	41,80	40	68,68
20	347,0	324,71	40	16,99	40	46,84	40	77,02
21	363,0	340,82	40	18,85	40	52,15	40	85,84
22	379,0	356,98	40	20,80	40	57,75		
23	396,0	373,08	40	22,85	40	63,63	40	104,88
24	412,0	389,18	40	24,99	40	69,80		
25	428,0	405,33	40	27,23	40	76,24	40	125,81
26	444,0	421,44	40	29,56	40	82,97		
28	476,0	453,69	40	34,51	40	97,27		
30	508,0	486,00	40	39,84	40	112,70	40	186,37
32	541,0	518,27	40	45,54				
35	589,0	566,71	40	54,81	40	156,19	40	258,69
38	638,0	615,16	40	64,93	40	185,67	40	307,73
40	670,0	647,47	40	72,16	40	206,73		
45	751,0	728,24	40	91,87	40	265,32	40	438,64
50	832,0	809,04	40	113,96	40	328,95	40	549,27
57	945,0	922,16	40	148,86	40	431,27	40	716,72
60	993,0	970,65	40	165,24				
76	1252,0	1229,27	40	267,00	40	757,78	40	1295,64