

Catalogo pulegge dentate T e AT passo metrico



- Trasmissioni Industriali S.a.s. -

Via Lago di Annone, 15 36015 Z.I. Schio (VI) Tel. 0445/500142-500011
Fax. 0445/500018

info@trasmissioniindustriali.com

NUOVO SITO www.trasmissioniindustriali.com

P U L E G G E D E N T A T E P A S S O M E T R I C O " T "

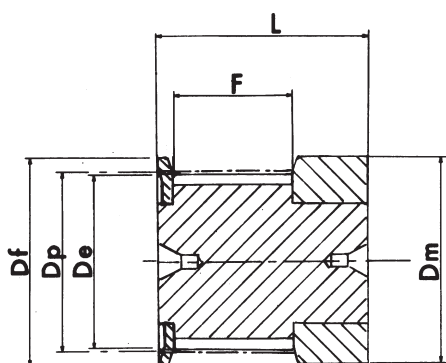

ESECUZIONE 0F

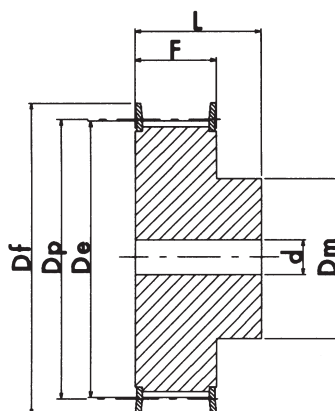

ESECUZIONE 1F

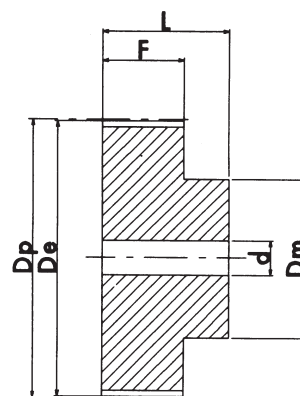

ESECUZIONE 2

Esempio di come identificare una puleggia: 31 T10 25

Larghezza puleggia (mm) 31
 Passo puleggia (mm) T10
 N. denti puleggia 25

MATERIALE: ALLUMINIO adatto per l'ossidazione dura a spessore.

A richiesta si costruiscono pulegge e barre passo T20

2.5 (Passo 2.5mm) PER CINGHIA LARGHEZZA 6mm

ALLUMINIO

DESCRIZIONE	ESEC.	N. denti	Dp	De	Df	Dm	F	L	d	FLANGIA N.
16 T2.5 12	0F	12	9.60	9.00	13.0	13	9	16	-	501
16 T2.5 14	0F	14	11.20	10.60	15.0	15	9	16	-	502
16 T2.5 15	0F	15	12.00	11.40	15.0	15	9	16	-	502
16 T2.5 16	0F	16	12.80	12.20	16.0	16	9	16	-	503
16 T2.5 18	1F	18	14.40	13.80	17.5	10	10	16	-	504
16 T2.5 19	1F	19	15.20	14.60	20.0	10	10	16	-	505
16 T2.5 20	1F	20	16.00	15.40	20.0	11	10	16	-	505
16 T2.5 22	1F	22	17.60	17.00	22.0	11	10	16	-	512
16 T2.5 24	1F	24	19.15	18.55	22.0	12	10	16	4	512
16 T2.5 25	1F	25	19.95	19.35	25.0	13	10	16	4	506
16 T2.5 26	1F	26	20.75	20.15	26.0	14	10	16	4	507
16 T2.5 28	1F	28	22.35	21.75	26.0	14	10	16	4	507
16 T2.5 30	1F	30	23.95	23.35	26.0	16	10	16	6	508
16 T2.5 32	1F	32	25.55	24.95	32.0	16	10	16	6	509
16 T2.5 36	1F	36	28.75	28.10	36.0	20	10	16	6	510
16 T2.5 40	1F	40	31.90	31.30	38.0	22	10	16	6	511
16 T2.5 44	2	44	35.10	34.50	-	24	10	16	6	-
16 T2.5 48	2	48	38.30	37.70	-	26	10	16	6	-
16 T2.5 60	2	60	47.85	47.25	-	34	10	16	8	-

PULEGGE DENTATE PASSO METRICO "T"

T 5 (Passo 5mm) PER CINGHIA LARGHEZZA 10mm

ALLUMINIO	DESCRIZIONE	ESEC.	N. denti	Dp	De	Df	Dm	F	L	d	FLANGIA N.
	21 T5 10	1F	10	15.92	15.05	19.5	8	15	21	-	3
	21 T5 12	1F	12	19.10	18.25	23.0	11	15	21	-	1
	21 T5 14	1F	14	22.29	21.45	25.0	13	15	21	-	2
	21 T5 15	1F	15	23.88	23.05	28.0	16	15	21	6	4
	21 T5 16	1F	16	25.47	24.60	32.0	18	15	21	6	5
	21 T5 18	1F	18	28.65	27.80	32.0	20	15	21	6	6
	21 T5 19	1F	19	30.25	29.40	36.0	22	15	21	6	8
	21 T5 20	1F	20	31.83	31.00	36.0	23	15	21	6	8
	21 T5 22	1F	22	35.02	34.15	38.0	24	15	21	6	9
21 T5 24	1F	24	38.21	37.40	42.0	26	15	21	6	13	
21 T5 25	1F	25	39.80	38.95	44.0	26	15	21	6	12	
21 T5 26	1F	26	41.39	40.60	44.0	26	15	21	6	12	
21 T5 27	1F	27	42.98	42.20	48.0	30	15	21	8	11	
21 T5 28	1F	28	44.58	43.75	48.0	32	15	21	8	11	
21 T5 30	1F	30	47.76	46.95	51.0	34	15	21	8	16	
21 T5 32	1F	32	50.94	50.10	54.0	38	15	21	8	18	
21 T5 36	1F	36	57.31	56.45	64.0	38	15	21	8	23	
21 T5 40	1F	40	63.66	62.85	66.5	40	15	21	8	24	
21 T5 42	1F	42	66.86	66.00	70.0	40	15	21	8	26	
21 T5 44	2	44	70.05	69.20	-	45	15	21	8	-	
21 T5 48	2	48	76.42	75.55	-	50	15	21	8	-	
21 T5 60	2	60	95.52	94.65	-	65	15	21	8	-	

T 5 (Passo 5mm) PER CINGHIA LARGHEZZA 16mm

ALLUMINIO	DESCRIZIONE	ESEC.	N. denti	Dp	De	Df	Dm	F	L	d	FLANGIA N.
	27 T5 10	1F	10	15.92	15.05	19.5	8	21	27	-	3
	27 T5 12	1F	12	19.10	18.25	23.0	11	21	27	-	1
	27 T5 14	1F	14	22.29	21.45	25.0	13	21	27	-	2
	27 T5 15	1F	15	23.88	23.05	28.0	16	21	27	6	4
	27 T5 16	1F	16	25.47	24.60	32.0	18	21	27	6	5
	27 T5 18	1F	18	28.65	27.80	32.0	20	21	27	6	6
	27 T5 19	1F	19	30.25	29.40	36.0	22	21	27	6	8
	27 T5 20	1F	20	31.83	31.00	36.0	23	21	27	6	8
	27 T5 22	1F	22	35.02	34.15	38.0	24	21	27	6	9
27 T5 24	1F	24	38.21	37.40	42.0	26	21	27	6	13	
27 T5 25	1F	25	39.80	38.95	44.0	26	21	27	6	12	
27 T5 26	1F	26	41.39	40.60	44.0	26	21	27	6	12	
27 T5 27	1F	27	42.98	42.20	48.0	30	21	27	8	11	
27 T5 28	1F	28	44.58	43.75	48.0	32	21	27	8	11	
27 T5 30	1F	30	47.76	46.95	51.0	34	21	27	8	16	
27 T5 32	1F	32	50.94	50.10	54.0	38	21	27	8	18	
27 T5 36	1F	36	57.31	56.45	64.0	38	21	27	8	23	
27 T5 40	1F	40	63.66	62.85	66.5	40	21	27	8	24	
27 T5 42	1F	42	66.86	66.00	70.0	40	21	27	8	26	
27 T5 44	2	44	70.05	69.20	-	45	21	27	8	-	
27 T5 48	2	48	76.42	75.55	-	50	21	27	8	-	
27 T5 60	2	60	95.52	94.65	-	65	21	27	8	-	

T 5 (5mm Passo) PER CINGHIA LARGHEZZA 25mm

ALLUMINIO	DESCRIZIONE	ESEC.	N. denti	Dp	De	Df	Dm	F	L	d	FLANGIA N.
	36 T5 10	1F	10	15.92	15.05	19.5	8	30	36	-	3
	36 T5 12	1F	12	19.10	18.25	23.0	11	30	36	-	1
	36 T5 14	1F	14	22.29	21.45	25.0	13	30	36	-	2
	36 T5 15	1F	15	23.88	23.05	28.0	16	30	36	6	4
	36 T5 16	1F	16	25.47	24.60	32.0	18	30	36	6	5
	36 T5 18	1F	18	28.65	27.80	32.0	20	30	36	6	6
	36 T5 19	1F	19	30.25	29.40	36.0	22	30	36	6	8
	36 T5 20	1F	20	31.83	31.00	36.0	23	30	36	6	8
	36 T5 22	1F	22	35.02	34.15	38.0	24	30	36	6	9
36 T5 24	1F	24	38.21	37.40	42.0	26	30	36	8	13	
36 T5 25	1F	25	39.80	38.95	44.0	26	30	36	8	12	
36 T5 26	1F	26	41.39	40.60	44.0	26	30	36	8	12	
36 T5 27	1F	27	42.98	42.20	48.0	30	30	36	8	11	
36 T5 28	1F	28	44.58	43.75	48.0	32	30	36	8	11	
36 T5 30	1F	30	47.76	46.95	51.0	34	30	36	8	16	
36 T5 32	1F	32	50.94	50.10	54.0	38	30	36	8	18	
36 T5 36	1F	36	57.31	56.45	64.0	38	30	36	8	23	
36 T5 40	1F	40	63.66	62.85	66.5	40	30	36	8	24	
36 T5 42	1F	42	66.86	66.00	70.0	40	30	36	8	26	
36 T5 44	2	44	70.05	69.20	-	45	30	36	8	-	
36 T5 48	2	48	76.42	75.55	-	50	30	36	8	-	
36 T5 60	2	60	95.52	94.65	-	65	30	36	8	-	

PULEGGE DENTATE PASSO METRICO "T"

T 10 (Passo 10mm) PER CINGHIA LARGHEZZA 16mm

DESCRIZIONE	ESEC.	N. denti	Dp	De	Df	Dm	F	L	d	FLANGIA N.
31 T10 12	1F	12	38.20	36.35	42	28	21	31	6	13
31 T10 14	1F	14	44.56	42.70	48	32	21	31	8	11
31 T10 15	1F	15	47.75	45.90	51	32	21	31	8	16
31 T10 16	1F	16	50.93	49.10	54	35	21	31	8	18
31 T10 18	1F	18	57.29	55.45	60	40	21	31	8	21
31 T10 19	1F	19	60.48	58.65	66	44	21	31	8	24
31 T10 20	1F	20	63.66	61.80	66	46	21	31	8	24
31 T10 22	1F	22	70.03	68.20	75	52	21	31	8	27
31 T10 24	1F	24	76.39	74.55	83	58	21	31	8	29
31 T10 25	1F	25	79.58	77.75	83	60	21	31	8	29
31 T10 26	1F	26	82.76	80.90	87	60	21	31	8	31
31 T10 27	1F	27	85.95	84.10	91	60	21	31	8	32
31 T10 28	1F	28	89.12	87.25	93	60	21	31	8	33
31 T10 30	1F	30	95.49	93.65	102	60	21	31	8	35
31 T10 32	1F	32	101.86	100.00	106	65	21	31	10	38
31 T10 36	1F	36	114.59	112.75	119	70	21	31	10	43
31 T10 40	1F	40	127.32	125.45	131	80	21	31	10	47
31 T10 44	2	44	140.05	138.20	-	88	21	31	10	-
31 T10 48	2	48	152.78	150.95	-	95	21	31	16	-
31 T10 60	2	60	190.98	189.10	-	110	21	31	16	-

ALLUMINIO

T 10 (Passo 10mm) PER CINGHIA LARGHEZZA 25mm

DESCRIZIONE	ESEC.	N. denti	Dp	De	Df	Dm	F	L	d	FLANGIA N.
40 T10 12	1F	12	38.20	36.35	42	28	30	40	6	13
40 T10 14	1F	14	44.56	42.70	48	32	30	40	8	11
40 T10 15	1F	15	47.75	45.90	51	32	30	40	8	16
40 T10 16	1F	16	50.93	49.10	54	35	30	40	8	18
40 T10 18	1F	18	57.29	55.45	60	40	30	40	8	21
40 T10 19	1F	19	60.48	58.65	66	44	30	40	8	24
40 T10 20	1F	20	63.66	61.80	66	46	30	40	8	24
40 T10 22	1F	22	70.03	68.20	75	52	30	40	8	27
40 T10 24	1F	24	76.39	74.55	83	58	30	40	8	29
40 T10 25	1F	25	79.58	77.75	83	60	30	40	8	29
40 T10 26	1F	26	82.76	80.90	87	60	30	40	8	31
40 T10 27	1F	27	85.95	84.10	91	60	30	40	8	32
40 T10 28	1F	28	89.12	87.25	93	60	30	40	8	33
40 T10 30	1F	30	95.49	93.65	102	60	30	40	8	35
40 T10 32	1F	32	101.86	100.00	106	65	30	40	10	38
40 T10 36	1F	36	114.59	112.75	119	70	30	40	10	43
40 T10 40	1F	40	127.32	125.45	131	80	30	40	10	47
40 T10 44	2	44	140.05	138.20	-	88	30	40	10	-
40 T10 48	2	48	152.78	150.95	-	95	30	40	16	-
40 T10 60	2	60	190.98	189.15	-	110	30	40	16	-

ALLUMINIO

A richiesta si costruiscono pulegge e barre passo T20

PULEGGE DENTATE PASSO METRICO "T"

T 10 (Passo 10mm) PER CINGHIA LARGHEZZA 32mm

ALLUMINIO

DESCRIZIONE	ESEC.	N. denti	Dp	De	Df	Dm	F	L	d	FLANGIA N.
47 T10 18	1F	18	57.29	55.45	60	40	37	47	10	21
47 T10 19	1F	19	60.48	58.60	66	44	37	47	10	24
47 T10 20	1F	20	63.66	61.80	66	46	37	47	12	24
47 T10 22	1F	22	70.03	68.20	75	52	37	47	12	27
47 T10 24	1F	24	76.39	74.55	83	58	37	47	12	29
47 T10 25	1F	25	79.58	77.75	83	60	37	47	12	29
47 T10 26	1F	26	82.76	80.90	87	60	37	47	12	31
47 T10 27	1F	27	85.95	84.10	91	60	37	47	12	32
47 T10 28	1F	28	89.12	87.25	93	60	37	47	12	33
47 T10 30	1F	30	95.49	93.65	102	60	37	47	12	35
47 T10 32	1F	32	101.86	100.00	106	65	37	47	12	38
47 T10 36	1F	36	114.59	112.75	119	70	37	47	16	43
47 T10 40	1F	40	127.32	125.45	131	80	37	47	16	47
47 T10 44	2	44	140.05	138.20	-	88	37	47	16	-
47 T10 48	2	48	152.78	150.95	-	95	37	47	16	-
47 T10 60	2	60	190.98	189.10	-	110	37	47	16	-

T 10 (Passo 10mm) PER CINGHIA LARGHEZZA 50mm

ALLUMINIO

DESCRIZIONE	ESEC.	N. denti	Dp	De	Df	Dm	F	L	d	FLANGIA N.
66 T10 18	1F	18	57.29	55.45	60	40	56	66	10	21
66 T10 19	1F	19	60.48	58.65	66	44	56	66	10	24
66 T10 20	1F	20	63.66	61.80	66	46	56	66	12	24
66 T10 22	1F	22	70.03	68.20	75	52	56	66	12	27
66 T10 24	1F	24	76.39	74.55	83	58	56	66	12	29
66 T10 25	1F	25	79.58	77.70	83	60	56	66	12	29
66 T10 26	1F	26	82.76	80.90	87	60	56	66	12	31
66 T10 27	1F	27	85.95	84.10	91	60	56	66	12	32
66 T10 28	1F	28	89.12	87.25	93	60	56	66	12	33
66 T10 30	1F	30	95.49	93.65	102	60	56	66	12	35
66 T10 32	1F	32	101.86	100.00	106	65	56	66	12	38
66 T10 36	1F	36	114.59	112.75	119	70	56	66	16	43
66 T10 40	1F	40	127.32	125.45	131	80	56	66	16	47
66 T10 44	2	44	140.05	138.20	-	88	56	66	16	-
66 T10 48	2	48	152.78	150.95	-	95	56	66	16	-
66 T10 60	2	60	190.98	189.10	-	110	56	66	16	-

A richiesta si costruiscono pulegge e barre passo T20

PULEGGIE PER CINGHIE DENTATE PASSO METRICO "AT"

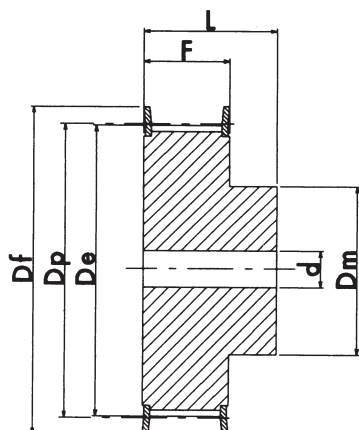

ESECUZIONE 1F

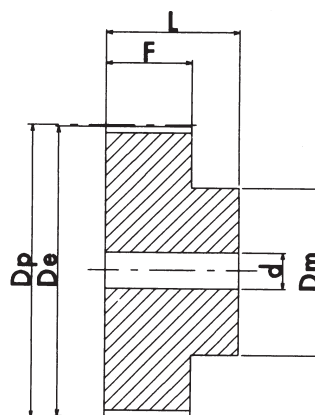

ESECUZIONE 2

Esempio di come identificare una puleggia:
21 AT5 25

Larghezza puleggia (mm) **21**
 Passo puleggia (mm) **AT5**
 N. denti puleggia **25**

MATERIALE: ALLUMINIO adatto per l'ossidazione dura a spessore.

AT5 (Passo 5 mm) PER CINGHIA LARGHEZZA 10 mm

ALLUMINIO

DESCRIZIONE	ESEC.	N. denti	Dp	De	Df	Dm	F	L	d	FLANGIA N.
21 AT5 12	1F	12	19.10	17.85	23.0	11	15	21	-	1
21 AT5 14	1F	14	22.29	21.05	25.0	13	15	21	-	2
21 AT5 15	1F	15	23.88	22.65	28.0	16	15	21	6	4
21 AT5 16	1F	16	25.47	24.20	32.0	18	15	21	6	5
21 AT5 18	1F	18	28.65	27.40	32.0	20	15	21	6	6
21 AT5 19	1F	19	30.25	29.00	36.0	22	15	21	6	8
21 AT5 20	1F	20	31.83	30.60	36.0	23	15	21	6	8
21 AT5 22	1F	22	35.02	33.85	38.0	24	15	21	6	9
21 AT5 24	1F	24	38.21	37.00	42.0	26	15	21	6	13
21 AT5 25	1F	25	39.80	38.60	44.0	26	15	21	6	12
21 AT5 26	1F	26	41.39	40.20	44.0	26	15	21	6	12
21 AT5 27	1F	27	42.98	41.80	48.0	30	15	21	8	11
21 AT5 28	1F	28	44.58	43.35	48.0	32	15	21	8	11
21 AT5 30	1F	30	47.76	46.55	51.0	34	15	21	8	16
21 AT5 32	1F	32	50.94	49.70	54.0	38	15	21	8	18
21 AT5 36	1F	36	57.31	56.05	64.0	38	15	21	8	23
21 AT5 40	1F	40	63.66	62.45	66.5	40	15	21	8	24
21 AT5 42	1F	42	66.86	65.60	70.0	40	15	21	8	26
21 AT5 44	2	44	70.05	68.80	-	45	15	21	8	-
21 AT5 48	2	48	76.42	75.15	-	50	15	21	8	-
21 AT5 60	2	60	95.52	94.25	-	65	15	21	8	-

PULEGGE PER CINGHIE DENTATE PASSO METRICO "AT"

AT5 (Passo 5 mm) PER CINGHIA LARGHEZZA 16 mm

DESCRIZIONE	ESEC.	N. denti	Dp	De	Df	Dm	F	L	d	FLANGIA N.
27 AT5 12	1F	12	19.10	17.85	23.0	11	21	27	-	1
27 AT5 14	1F	14	22.29	21.05	25.0	13	21	27	-	2
27 AT5 15	1F	15	23.88	22.65	28.0	16	21	27	6	4
27 AT5 16	1F	16	25.47	24.20	32.0	18	21	27	6	5
27 AT5 18	1F	18	28.65	27.40	32.0	20	21	27	6	6
27 AT5 19	1F	19	30.25	29.00	36.0	22	21	27	6	8
27 AT5 20	1F	20	31.83	30.60	36.0	23	21	27	6	8
27 AT5 22	1F	22	35.02	33.85	38.0	24	21	27	6	9
27 AT5 24	1F	24	38.21	37.00	42.0	26	21	27	6	13
27 AT5 25	1F	25	39.80	38.60	44.0	26	21	27	6	12
27 AT5 26	1F	26	41.39	40.20	44.0	26	21	27	6	12
27 AT5 27	1F	27	42.98	41.80	48.0	30	21	27	8	11
27 AT5 28	1F	28	44.58	43.35	48.0	32	21	27	8	11
27 AT5 30	1F	30	47.76	46.55	51.0	34	21	27	8	16
27 AT5 32	1F	32	50.94	49.70	54.0	38	21	27	8	18
27 AT5 36	1F	36	57.31	56.05	64.0	38	21	27	8	23
27 AT5 40	1F	40	63.66	62.45	66.5	40	21	27	8	24
27 AT5 42	1F	42	66.86	65.60	70	40	21	27	8	26
27 AT5 44	2	44	70.05	68.80	-	45	21	27	8	-
27 AT5 48	2	48	76.42	75.15	-	50	21	27	8	-
27 AT5 60	2	60	95.52	94.25	-	65	21	27	8	-

ALLUMINIO

AT5 (Passo 5 mm) PER CINGHIA LARGHEZZA 25 mm

DESCRIZIONE	ESEC.	N. denti	Dp	De	Df	Dm	F	L	d	FLANGIA N.
36 AT5 12	1F	12	19.10	17.85	23.0	11	30	36	-	1
36 AT5 14	1F	14	22.29	21.05	25.0	13	30	36	-	2
36 AT5 15	1F	15	23.88	22.65	28.0	16	30	36	6	4
36 AT5 16	1F	16	25.47	24.20	32.0	18	30	36	6	5
36 AT5 18	1F	18	28.65	27.40	32.0	20	30	36	6	6
36 AT5 19	1F	19	30.25	29.00	36.0	22	30	36	6	8
36 AT5 20	1F	20	31.83	30.60	36.0	23	30	36	6	8
36 AT5 22	1F	22	35.02	33.85	38.0	24	30	36	6	9
36 AT5 24	1F	24	38.21	37.00	42.0	26	30	36	6	13
36 AT5 25	1F	25	39.80	38.60	44.0	26	30	36	6	12
36 AT5 26	1F	26	41.39	40.20	44.0	26	30	36	6	12
36 AT5 27	1F	27	42.98	41.80	48.0	30	30	36	8	11
36 AT5 28	1F	28	44.58	43.35	48.0	32	30	36	8	11
36 AT5 30	1F	30	47.76	46.55	51.0	34	30	36	8	16
36 AT5 32	1F	32	50.94	49.70	54.0	38	30	36	8	18
36 AT5 36	1F	36	57.31	56.05	64.0	38	30	36	8	23
36 AT5 40	1F	40	63.66	62.45	66.5	40	30	36	8	24
36 AT5 42	1F	42	66.86	65.60	70.0	40	30	36	8	26
36 AT5 44	2	44	70.05	68.80	-	45	30	36	8	-
36 AT5 48	2	48	76.42	75.15	-	50	30	36	8	-
36 AT5 60	2	60	95.52	94.25	-	65	30	36	8	-

ALLUMINIO

A richiesta si costruiscono pulegge e barre passo AT20

PULEGGE PER CINGHIE DENTATE PASSO METRICO "AT"

AT10 (Passo 10 mm) PER CINGHIE LARGHEZZA 16 mm

DESCRIZIONE	ESEC.	N. denti	Dp	De	Df	Dm	F	L	d	FLANGIA
										N.
31 AT10 15	1F	15	47.75	45.90	51	32	21	31	8	16
31 AT10 16	1F	16	50.93	49.05	54	35	21	31	8	18
31 AT10 18	1F	18	57.29	55.45	60	40	21	31	8	21
31 AT10 19	1F	19	60.48	58.60	66.5	44	21	31	8	24
31 AT10 20	1F	20	63.66	61.80	66.5	46	21	31	8	24
31 AT10 22	1F	22	70.03	68.15	75	52	21	31	8	27
31 AT10 24	1F	24	76.39	74.55	83	58	21	31	8	29
31 AT10 25	1F	25	79.58	77.70	83	60	21	31	8	29
31 AT10 26	1F	26	82.76	80.90	87	60	21	31	8	31
31 AT10 27	1F	27	85.95	84.10	91	60	21	31	8	32
31 AT10 28	1F	28	89.12	87.25	93	60	21	31	8	33
31 AT10 30	1F	30	95.49	93.65	102	60	21	31	8	35
31 AT10 32	1F	32	101.86	100.00	106	65	21	31	10	38
31 AT10 36	1F	36	114.59	112.75	119	70	21	31	10	43
31 AT10 40	1F	40	127.32	125.45	131	80	21	31	10	47
31 AT10 44	2	44	140.05	138.20	-	88	21	31	10	-
31 AT10 48	2	48	152.78	150.95	-	95	21	31	16	-
31 AT10 60	2	60	190.98	189.10	-	110	21	31	16	-

ALLUMINIO

AT10 (Passo 10 mm) PER CINGHIA LARGHEZZA 25 mm

DESCRIZIONE	ESEC.	N. denti	Dp	De	Df	Dm	F	L	d	FLANGIA
										N.
40 AT10 15	1F	15	47.75	45.90	51	32	30	40	8	16
40 AT10 16	1F	16	50.93	49.05	54	35	30	40	8	18
40 AT10 18	1F	18	57.29	55.45	60	40	30	40	8	21
40 AT10 19	1F	19	60.48	58.60	66.5	44	30	40	8	24
40 AT10 20	1F	20	63.66	61.80	66.5	46	30	40	8	24
40 AT10 22	1F	22	70.03	68.15	75	52	30	40	8	27
40 AT10 24	1F	24	76.39	74.55	83	58	30	40	8	29
40 AT10 25	1F	25	79.58	77.70	83	60	30	40	8	29
40 AT10 26	1F	26	82.76	80.90	87	60	30	40	8	31
40 AT10 27	1F	27	85.95	84.10	91	60	30	40	8	32
40 AT10 28	1F	28	89.12	87.25	93	60	30	40	8	33
40 AT10 30	1F	30	95.49	93.65	102	60	30	40	8	35
40 AT10 32	1F	32	101.86	100.00	106	65	30	40	10	38
40 AT10 36	1F	36	114.59	112.75	119	70	30	40	10	43
40 AT10 40	1F	40	127.32	125.45	131	80	30	40	10	47
40 AT10 44	2	44	140.05	138.20	-	88	30	40	10	-
40 AT10 48	2	48	152.78	150.95	-	95	30	40	16	-
40 AT10 60	2	60	190.98	189.10	-	110	30	40	16	-

ALLUMINIO

A richiesta si costruiscono pulegge e barre passo AT20

P U L E G G E P E R C I N G H I E D E N T A T E P A S S O M E T R I C O " A T "

AT10 (Passo 10 mm) PER CINGHIA LARGHEZZA 32 mm

ALLUMINIO	DESCRIZIONE	ESEC.	N. denti	Dp	De	Df	Dm	F	L	d	FLANGIA N.
	47 AT10 18	1F	18	57.29	55.45	60	40	37	47	10	21
	47 AT10 19	1F	19	60.48	58.60	66.5	44	37	47	10	24
	47 AT10 20	1F	20	63.66	61.80	66.5	46	37	47	12	24
	47 AT10 22	1F	22	70.03	68.15	75	52	37	47	12	27
	47 AT10 24	1F	24	76.39	74.55	83	58	37	47	12	29
	47 AT10 25	1F	25	79.58	77.70	83	60	37	47	12	29
	47 AT10 26	1F	26	82.76	80.90	87	60	37	47	12	31
	47 AT10 27	1F	27	85.95	84.10	91	60	37	47	12	32
	47 AT10 28	1F	28	89.12	87.25	93	60	37	47	12	33
	47 AT10 30	1F	30	95.49	93.65	102	60	37	47	12	35
	47 AT10 32	1F	32	101.86	100.00	106	65	37	47	12	38
	47 AT10 36	1F	36	114.59	112.75	119	70	37	47	16	43
	47 AT10 40	1F	40	127.32	125.45	131	80	37	47	16	47
	47 AT10 44	2	44	140.05	138.20	-	88	37	47	16	-
	47 AT10 48	2	48	152.78	150.95	-	95	37	47	16	-
47 AT10 60	2	60	190.98	189.10	-	110	37	47	16	-	

AT10 (Passo 10 mm) PER CINGHIA LARGHEZZA 50 mm

ALLUMINIO	DESCRIZIONE	ESEC.	N. denti	Dp	De	Df	Dm	F	L	d	FLANGIA N.
	66 AT10 18	1F	18	57.29	55.45	60	40	56	66	10	21
	66 AT10 19	1F	19	60.48	58.60	66.5	44	56	66	10	24
	66 AT10 20	1F	20	63.66	61.80	66.5	46	56	66	12	24
	66 AT10 22	1F	22	70.03	68.15	75	52	56	66	12	27
	66 AT10 24	1F	24	76.39	74.55	83	58	56	66	12	29
	66 AT10 25	1F	25	79.58	77.70	83	60	56	66	12	29
	66 AT10 26	1F	26	82.76	80.90	87	60	56	66	12	31
	66 AT10 27	1F	27	85.95	84.10	91	60	56	66	12	32
	66 AT10 28	1F	28	89.12	87.25	93	60	56	66	12	33
	66 AT10 30	1F	30	95.49	93.65	102	60	56	66	12	35
	66 AT10 32	1F	32	101.86	100.00	106	65	56	66	12	38
	66 AT10 36	1F	36	114.59	112.75	119	70	56	66	16	43
	66 AT10 40	1F	40	127.32	125.45	131	80	56	66	16	47
	66 AT10 44	2	44	140.05	138.20	-	88	56	66	16	-
	66 AT10 48	2	48	152.78	150.95	-	95	56	66	16	-
66 AT10 60	2	60	190.98	189.10	-	110	56	66	16	-	

A richiesta si costruiscono pulegge e barre passo AT20